



DELIVERABLE

D6.1

Project details

Project Title	Development of an Efficient Microwave System for Material Transformation in energy INTensive processes for an improved Yield.		
Project Acronym	DESTINY		
Grant Agreement No.	820783	Duration	42 months
Project Start Date	01-10-2018	Project End Date	31-03-2022

Document details

WP:	6	WP Leader:	CIAOTECH (Beneficiary #12)
WP Title:	Dissemination, Exploitation and Market Penetration		
Task:	6.1. –	Task Leader:	CIAOTECH (Beneficiary #12)
Task Title:	Value Chain Stakeholder and Market Analysis		
Deliverable No.	D6.1		
Deliverable Title	Market Study		
Dissemination level	PUBLIC		
Written By	CIAOTECH (Beneficiary #12)		
Contributing beneficiary(ies)	CIAOTECH (Beneficiary #12) / PNO-ES (Beneficiary #15)		
Approved by	KERABEN (Beneficiary #1) / CEINNMAT (Beneficiary #2)		
Status	Version 1.0-00		
Date	06/11/2019		



Document history

V	DATE	CREATED BY	REVISED BY	APPROVED BY
0.1	13/05/2019	CIAOTECH & PNO-ES		
0.2	10/09/2019		CIAOTECH & PNO-ES	
0.3	30/09/2019			CIAOTECH
0.4	23/10/2019		CIAOTECH & PNO-ES	CIAOTECH
1.0	06/11/2019	CIAOTECH & PNO-ES	KERABEN&CEINNMAT	KERABEN&CEINNMAT



Table of Content

1	SUMMARY	8
2	PROJECT INTRODUCTION	9
3	OBJETIVES OF THIS DELIVERABLE	10
4	CONNECTION TO OTHER TASKS	11
5	DESTINY MARKET ANALYSIS	12
5.1	METHODOLOGY.....	12
5.1.1	Scope of the report.....	12
5.2	CEMENT SECTOR MARKET ANALYSIS	13
5.2.1	CEMENT Demand and Supply Analysis.....	13
5.2.1.1	Global CEMENT Market Demand	13
5.2.1.2	Europe CEMENT Market Demand	16
5.2.2	CEMENT Industry Key Players.....	19
5.2.3	CEMENT Industry Sector Description:	23
5.2.4	CEMENT Industry Externalities (completing a PESTLE analysis).....	31
5.3	STEEL SECTOR ANALYSIS.....	39
5.3.1	STEEL Market Demand and Supply Analysis.....	39
5.3.2	STEEL Industry Key Players	43
5.3.3	STEEL Industry Sector Description:.....	44
5.3.3.1	Employment & global turnover	44
5.3.3.2	Process Routes.....	45
5.3.3.3	Cross-sectoral Value-chain	46
5.3.3.4	Used Technologies.....	48
5.3.4	Zinc Market.....	54
5.3.5	STEEL Industry Externalities (completing a PESTLE analysis)	58
5.3.5.1	Environmental and Societal Impacts	58
5.3.5.2	Policy, Relevant Standards and Directives.....	59
5.3.5.3	Innovation trends in the sector (not from patents and projects)	62
5.4	CERAMIC SECTOR ANALYSIS.....	64
5.4.1	CERAMIC Market Demand and Supply Analysis.....	64



5.4.2	CERAMIC and PIGMENT Industry Key Players	68
5.4.3	CERAMIC and PIGMENT Sector Description:	71
5.4.4	CERAMIC and PIGMENT Industry Externalities (completing a PESTLE analysis)	74
6	Project Positioning – Preliminary analysis.....	80
7	RESULTS & CONCLUSIONS	82
7.1	RESULTS OVERVIEW	82
7.2	CONCLUSIONS AND NEXT STEPS	82
8	MAIN REFERENCES	83

List of Tables

Table 1.	World cement consumption and production	16
Table 2.	Cement consumption in Europe	17
Table 3.	Cement production in the world	19
Table 4.	Main key players market share.....	21
Table 5.	Assessment factors	25
Table 6.	Type of cement	27
Table 7.	Kiln technical characteristics.....	28
Table 8.	BAT emission level	35
Table 9:	EU total finished steel production by product (Source: Eurofer)	40
Table 10:	EU Steel consumption per Steel-using sectors and EU Steel Weighted Industrial Production (SWIP) index (Source: Eurofer).....	41
Table 11:	Market supply of finished steel products (source: Eurofer).....	42
Table 12:	EU Consumption, Imports and Exports of Scrap Steel, 2013-2017 (source: Eurofer)	42
Table 13:	EU steel scrap specifications.....	43
Table 14:	EU-28 steel industry key players.....	43
Table 15:	Other Europe steel industry key players	43
Table 16:	Steel value chain assessments.....	47
Table 17:	Energy required of key processes in Iron and Steel industry.	49
Table 18:	Main differences between BOF and EAF routes.....	50
Table 19:	EU crude steel output by production route, 2015-2017 (source: Eurofer)	50
Table 20:	Features of processes for ironmaking in steel industry.....	53
Table 21:	Global zinc production, 2015-2019 (source: ILZSG; Zinc Market Overview, Nexa)	54
Table 22:	Global refined zinc consumption, 2015-2019 (source: ILZSG; Zinc Market Overview, Nexa)	56
Table 23:	Global refined zinc market balance (source: ILZSG; Zinc Market Overview, Nexa)	57
Table 24:	Major global zinc producers (source: The Balance).....	58
Table 25:	Limit values relevant for iron and steel production from the existing Protocols to the Geneva Convention	60
Table 26:	BAT-associated emission levels from the UNECE Guidance Documents to the Gothenburg and the HM Protocol.....	61



List of Figures

Figure 1. Global Cement Market (tonnes), average calculated from multiple sources	14
Figure 2. Global Cement Market (Dollars).....	15
Figure 3. World Cement Production and Consumption	15
Figure 4. Europe Cement Market (Dollars).....	16
Figure 5. Cement Supply/Demand balance Europe	17
Figure 6. Cement consumption EU	18
Figure 7. Comparison of cement production and sales data from different sources	18
Figure 8. World cement production	20
Figure 9. Europe cement relative production between the main producers.....	20
Figure 10. Main world key players	21
Figure 11. Revenue cement main manufacturers	21
Figure 12. Turnover & Employment	23
Figure 13. Cement plant overview (source: https://nikopic.com/schneider-electric-1)	24
Figure 14. Value Chain	24
Figure 15. Cement production process	26
Figure 16. Preheat/Precalciner kiln type (source www.cementkilns.co.uk)	26
Figure 17. Total production of clinker for different kilns	29
Figure 18. Long Dry Kiln	29
Figure 19. Cement CO ₂ emissions in EU'	33
Figure 20. Total CO ₂ emissions by kiln type.....	33
Figure 21. Potential energy saving Source: ADVANCE-WP2 “A model guide for cement industry”	35
Figure 22. Thermal energy consumption by fuel type	36
Figure 23. Percentage of alternative fuels	37
Figure 24. 2050 perspectives through different technologies adoption.....	37
Figure 25. Cement producers: top assignees by production volume and emissions intensity	38
Figure 26. a) EU-28 steel production by country (Million tonnes), 2019; b) EU-28 steel production forecast (2019-2030)	39
Figure 27. Global steel production by region, 2019	40
Figure 28. Economic impacts of the EU Steel Industry, 2017 (source: Eurofer)	44
Figure 29. Steel Supply Chain (source: World Steel Association).....	45
Figure 30. Common steel value chain integrated with DK business	46
Figure 31. Technologies used for steelmaking	48
Figure 32. Steel industry production sites in EU, 2017 (source: Eurofer)	51
Figure 33. Direct reduction processes for iron (source: International Iron Metallics Association)	52
Figure 34. Typical Waelz Kiln Process (source: Global Steel Dust)	54
Figure 35: a) Zinc produced in mines, market share by region (source: Greenspec); b) Zinc produced from EAF dusts, by region (source: ILZSG)	55
Figure 36: Global refined zinc consumption, by region (source: ILZSG).....	56
Figure 37: a) Global refined zinc consumption, by application (source: ILZSG); b) Global refined zinc consumption, by final use (source: Zinc Market Overview, Nexa).....	56
Figure 38. CO ₂ emissions by steelmaking technologies	59
Figure 39. Technological maturity of decarbonization options (source: Energy Transitions).....	63
Figure 40. Global Ceramic Market.....	65
Figure 41. World Ceramic Production and Consumption'	65



Figure 42. European Ceramic market.....	66
Figure 43. Tile production (EU-28)	66
Figure 44. Ceramic industrial sectors production	67
Figure 45. Global Pigment market.....	67
Figure 46. Top countries.....	68
Figure 47. Market shares Pigments	69
Figure 48. Pigments Key Players.....	70
Figure 49. Ceramic brick process	71
Figure 50. Pigment type and processing	72
Figure 51. Pigment Value chain	72
Figure 52. Ceramic Tiles Value chain	73
Figure 53. Type of kilns and Fireless processes.....	73
Figure 54. CO ₂ emitted during 2010.....	74
Figure 55. CO ₂ Cement process.	75
Figure 56. Specific consumption for different sectors	75
Figure 57. BAT emission level.....	76
Figure 58. Technological innovation trends	78
Figure 59. CO ₂ emission reduction between 2010 and 2050	79
Figure 60. Project Pilots concept.....	80
Figure 61. Scratch Lean model canvas.....	81

Abbreviations and acronyms

- [KPI] Key Performance Indicator
- [BAT] Best Available Techniques
- [SDGs] Sustainable Development Goals
- [SWOT] Strengths, Weaknesses, Opportunities and Threats
- [IPR] Intellectual Property Rights
- [CAGR] Compounded Average Growth Rate
- [GBFS] Granulated Blast Furnace Slag
- [WBCSD] World Business Council for Sustainable Development
- [SD] Sustainable Development
- [ETS] Emission Trading System
- [CSI] Cement Sustainability Initiative
- [IPPC] Integrated Pollution Prevention and Control
- [CCS] Carbon Capture and Storage
- [CCU] Carbon Capture and Utilisation
- [SWIP] Steel-Weighted Industrial Production



[OHF] Open-Hearth Furnace

[BOF] Basic-Oxygen Furnace

[DRI] Direct Reduced Iron

[BF] Blast Furnace

[EAF] Electric-Arc Furnace

[GVA] Gross value added

[ULCOS] Ultra-Low Carbon dioxide (CO₂) Steelmaking

[TGR BF] Top gas recycling blast furnace

[CICP] complex inorganic coloured pigments

[LPG] liquefied petroleum gas

[NG] natural gas

[CP] ceramic pigments

Disclaimer

This deliverable may be subject to final acceptance by the European Commission. The results of these deliverables reflect only the author's view and the Commission is not responsible for any use that may be made of the information it contains

Statement for open documents & Copyrights.

This document is property of the DESTINY Consortium. The content of all or parts of these documents can be used and distributed provided that the DESTINY project and the document are properly referenced.

CIAOTECH (PNO Consultants) and the DESTINY consortium are keen on ensuring that all information in this document is correct and fairly stated but does not accept liability for any errors or omissions.

At the best of our knowledge, all third-party literary (articles/studies/reports/etc. or excerpts thereof) or artistic (photos/graphs/drawings/etc.) used to support this document are correctly cited and acknowledged. If the reader should find something not compliant, an additional courtesy acknowledgement or correction can be made to this version thereof.



1 SUMMARY

The present document constitutes Deliverable *D6.1: "Market Report"* in the framework of the DESTINY project entitled *"Development of an Efficient Microwave System for Material Transformation in energy Intensive processes for an improved Yield"*

WP6 envelopes all the activities related to market and stakeholders' knowledge and their engagement during and after the project. The final aim is ensuring a large exploitation and market penetration for microwave technology-based plants and other relevant exploitable results from the project.

In general, WP6 will:

- ▶ **Assess and define the relevant actors in the Value Chain and Market** connected to DESTINY.
- ▶ Study the market and **define possible business approaches** enabled by the new DESTINY technology.
- ▶ Bring on **effective engagement of the identified stakeholders**
- ▶ **Build and monitor an effective dissemination** and communication plan
- ▶ Support **IPR and exploitation**

The main specific objectives are:

- ▶ Study in detail the market, to find the best positioning for DESTINY's innovative plant concepts (e.g. mobile plants), in the cement, ceramic and steel sectors, to ensure the largest applicability of the concepts beyond the project consortium
- ▶ Support the Development of breakthrough innovative business models based on an exploratory business research and knowledge sharing and define a business plan for producers
- ▶ Defining and Building a Stakeholder community to engage and define the best communication and dissemination actions
- ▶ Propose concrete exploitation and IPR management for technology developers to sell the solution worldwide
- ▶ Assess sustainability aspects in terms of the life cycle energetic/environmental/economic and social impacts
- ▶ Development of decision support schemes reflecting decision-making aspects of potential stakeholders.



2 PROJECT INTRODUCTION

The DESTINY project aims to realize a functional, green and energy saving, scalable and replicable solution, employing microwave energy for continuous material processing in energy intensive industries. The target is to develop and demonstrate a new concept of firing granular feedstock for materials transformation using full microwave heating as alternative and complement to the existing conventional production.

The DESTINY system is conceived as cellular kilns in mobile modular plant, with significant advantages in terms of resource and energy efficiency, flexibility, replicability and scalability with reduced environmental footprint.

The DESTINY concept will be proved in two demo sites located in Spain and Germany, covering high energy demanding sectors of strategic interest as Ceramic (Pigments), Cement (Calcined clay) and Steel (Sinter, Iron Pellets/ DRI, ZnO), to validate the critical parameters of the developed technology in relevant environment (TRL 6). It will be implemented 2 feeding modules per demo site and 1 mobile microwave kiln module and product treatment.

Influence of the DESTINY solutions in terms of stability, process efficiency and characteristics of raw materials, intermediate/sub/final products will be investigated to improve performance of the industrial processes addressed and guarantee the required quality of products. Numerical simulation tools will be used to drive the design and support the testing activities.

The industrialization and sustainability of DESTINY high temperature microwave technology will be assessed through the evaluation of relevant KPIs, with Life Cycle Methodologies. With the final aim of ensuring a large exploitation and market penetration for DESTINY, technology-based solutions business model, economic viability and replicability analysis will be conducted. For guaranteeing industrial transferability appropriate exploitation and dissemination activities have been defined during and even after the end of the project.



3 OBJETIVES OF THIS DELIVERABLE

The specific objectives for Task 6.1 within the DESTINY project are:

- ▶ Provide a first **overview and support understanding of the potential market** for DESTINY's
- ▶ Identify **relevant value-chains** and stakeholders
- ▶ Find **relevant technology innovators**, competing solutions, similar research and innovation trends
- ▶ Set up the **base to study new business models** and developments for DESTINY technology

As explained in the next Chapter, in this document the approach is to provide a first necessary step to build a seamless set of analyses and support the partners in analysing a complex framework while proceeding with the R&D developments.

STUDY OBJECTIVES OF THIS REPORT ARE

- 1) **To Analyse and predict the size** of the global and European cement/steel/ceramic markets in terms of value and volume, supply and demand
- 2) **Identification of the key countries and players** according to standard economic indicators (e.g. production, consumption, supply and demand, turnover and value added, jobs etc...)
- 3) **Analysis of relevant technologies, production processes, standards and limits** (e.g. BAT – Best Available Techniques) in terms of performances and environmental KPIs
- 4) Assessment of the connected **value-chains**
- 5) Analysis of **externalities** such as socio-environmental impacts
- 6) Definition and collection of data about most known **future innovation trends**



4 CONNECTION TO OTHER TASKS

The market analysis performed and reported in this document is the first step in a series that will support DESTINY consortium in assessing, developing, connecting and bridging the gap to the market of the developed technologies and Key Exploitable Results developed during the project.

This objective will be supported by desktop studies, knowledge-based intelligence and live-action engagement of relevant identified stakeholders.

This first report is intended to be a compendium which relates in a one-stop-shop all the information about the 3 industries primary affected by DESTINY technology and represented within the consortium.

These data are intended to work as a base to:

- Brainstorm along with the partners and engage them in reflections (via interviews, calls or dedicated face-to-face meetings) about business relevance, project impacts and SWOT – Strengths, Weaknesses, Opportunities and Threats, in advance during the project, in order to pursue a better exploitation
- Assess the most affected value-chain branches (already clear or hidden) that could be interested or impacted by DESTINY technology, leading to revised and detailed business-cases
- Define the serviceable market from which defining the business potential of the project results and the project business plan (based on the business cases)
- Understand the innovation trends as a first base for a technology-based stakeholder analysis
- Be sure to include the regulatory and technological standard reference values and framework to be considered during the project
- Set the right background to think about where business model innovation can be needed the most and support the innovation of standard business models in the 3 target sectors
- Identify the relevant stakeholders and engage them to support the project exploitation with interviews and participation to project events, while also supporting the IPR strategy of the partners

Such activities and objectives represent the connection with tasks/subtasks 6.2, 6.3.2, 6.4 and 6.5 and also connect to WP7 via subtask 6.2.3

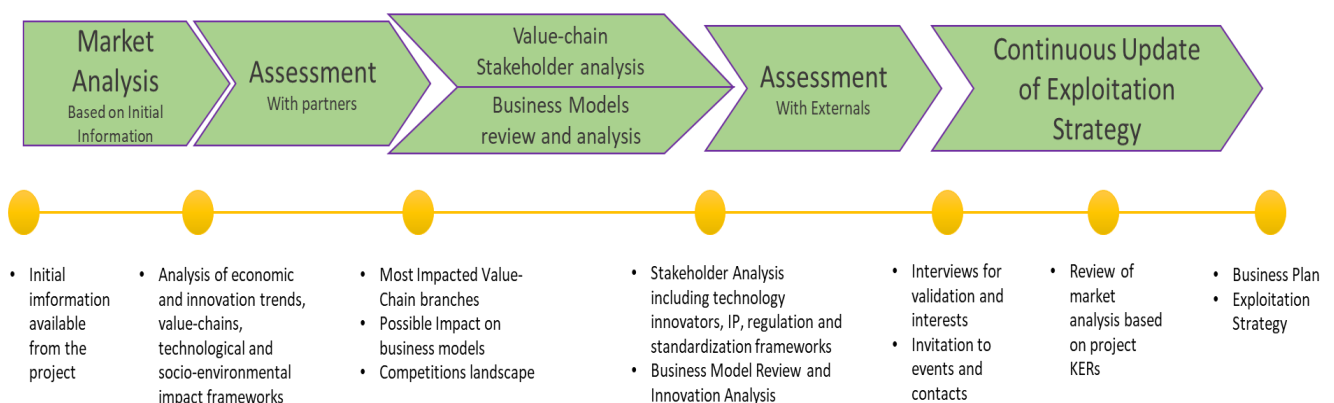

Figure A. Overview of the exploitation activities

5 DESTINY MARKET ANALYSIS

5.1 METHODOLOGY

The study to estimate the current size of the cement, steel and ceramic/pigment markets related to DESTINY is divided into extensive secondary research conducted to gather the necessary information, followed by robust analysis for the verification and extension of the available data.

Several sources have been used in the secondary research process, such as Cerame-Unie European Association of the Ceramic Industry, Cembureau European Association of the Cement Industry, The World Steel Association, The World Business Council for Sustainable Development, Global Cement & Concrete Association, scientific articles, annual reports, press releases, regulatory bodies documents and related databases.

For all the market projections two or more sources have been used in order to report an educated average value and have a constant data-check. This criterion has also been adopted when direct data was missing or had to be extended.

In order to complete the overall analysis process, data triangulation (e.g. by studying various factors and trends on both the supply and demand side) and market breakdown procedures were employed where applicable.

The innovation trends were also approached, considering mostly known technologies which can already be spotted on the web, general purpose articles and in technical press. A thorough verification and further deep-dive will be completed by observing funded R&D project and IP databases in the stakeholder analysis to come.

5.1.1 Scope of the report

Report Metric	Details
<i>Years considered for the study</i>	2018-2024
<i>Base year</i>	2018
<i>Forecast period</i>	2018-2030
<i>Units considered</i>	Value (Dollar- Euro) Volume (Sq.m)
<i>Segments</i>	Ceramic and Pigments
<i>Regions</i>	World and Europe

Report Metric	Details
<i>Years considered for the study</i>	2015-2019
<i>Base year</i>	2017
<i>Forecast period</i>	2016-2035
<i>Units considered</i>	Volume (tonne)
<i>Segments</i>	Steel
<i>Regions</i>	World and Europe

Report Metric	Details
<i>Years considered for the study</i>	2016-2025
<i>Base year</i>	2016
<i>Forecast period</i>	2016-2035
<i>Units considered</i>	Value (Dollar- Euro) Volume (tonne)
<i>Segments</i>	Cement
<i>Regions</i>	World and Europe



5.2 CEMENT SECTOR MARKET ANALYSIS



5.2.1 CEMENT Demand and Supply Analysis

Cement and concrete sectors face a considerable challenge: how to increase production to help roll out infrastructure services and structural while also achieving emissions reductions in line with global targets.

Cement manufacturing is a huge part of global emissions: the chemical and thermal combustion processes involved in the production of cement are a major source of CO₂, contributing around 8% of annual global release. Despite this, a substantial expansion of construction market is needed to meet the SDGs (Sustainable Development Goals), as expanding access to clean water and energy depends on replacing old and building new infrastructure.

The Global Commission on the Economy and Climate estimates that USD 90 trillion will be invested in infrastructure through to 2030, and that two-thirds of this investment will be in developing countries.

It also projects that, if developing countries expand their infrastructure to current average global levels, the production of the required materials alone will cumulatively emit 470 Gt of CO₂ by 2050.

Against this scenario, greenhouse gas emissions need to fall by around half by 2030 to meet the Paris Agreement goal of keeping global warming to well below 2°C above pre-industrial levels, and to pursue efforts to limit the temperature increase even further to 1.5°C. So, carbon-neutral or carbon-negative construction would be required everywhere from 2030 onwards, which implies the need to rapidly scale up the use of building materials with zero or negative emissions in the next decade.¹

5.2.1.1 Global CEMENT Market Demand

Cement is an inorganic binder and finely ground powder which when mixed with water show a reaction of hydration and forms a paste that sets and hardens. Cement is used as binder in combination with aggregates and water to form mortar and concrete. **Every year, more than 4 billion tonnes of cement are produced**, and this data is expected to grow, towed by emerging markets. Indeed, while China's cement production, a

¹<https://reader.chathamhouse.org/making-concrete-change-innovation-low-carbon-cement-and-concrete#introduction>

key driver of the market in recent years, may have reached its peak, urbanization in other industrializing countries such as India and Indonesia is likely to keep on boosting global demand. Some estimates project a threefold to fourfold increase in demand from developing countries in Asia by 2050.

Market forecasts show that the global size of the cement market is estimated to grow from almost 5 billion tonnes in 2020 up to 7.42 tonnes in 2035.^{2,3} It was valued at USD 355.6 billion in 2016 and it is expected to register a CAGR of 7.8% from 2017 to 2025.⁴ One of the major factors driving the growth of the cement market is the revival of the construction industry in the commercial, residential and infrastructural projects.

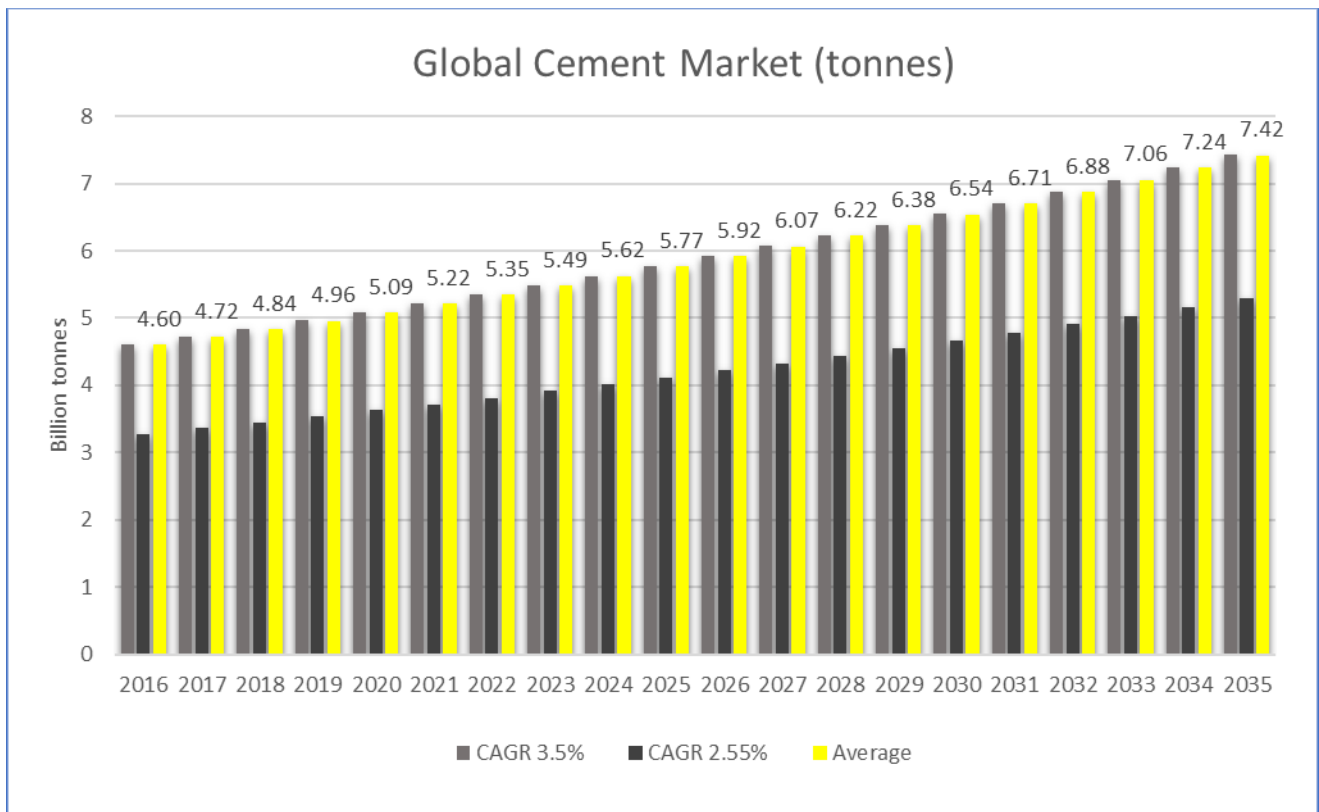

Figure 1. Global Cement Market (tonnes), average calculated from multiple sources

Currently, in most cases the cement industry produces more than what is consumed^{5,6} (see figure below) and this changes with geography. For example, in Europe in 2015, 167 million tonnes were produced but 123 tonnes were consumed, which means that production has exceeded the demand by 26% and this undoubtedly entails an economic loss for the sector: countries like the United States, Australia, and Saudi Arabia have instead shown a higher consumption (even if not excessive) to that produced.

² <https://www.imarcgroup.com/cement-manufacturing-plant>

³ Source: "Market Analysis in Destiny proposal"

⁴ <https://www.grandviewresearch.com/industry-analysis/cement-market>

⁵ https://www.aitecweb.com/Portals/1/Repository/Pubblico/Area%20Economica/Pubblicazioni%20AITEC/Rapporto_Annuale_2017.pdf?ver=2018-06-26-151502-207

⁶ <https://cembureau.eu/cement-101/key-facts-figures/>



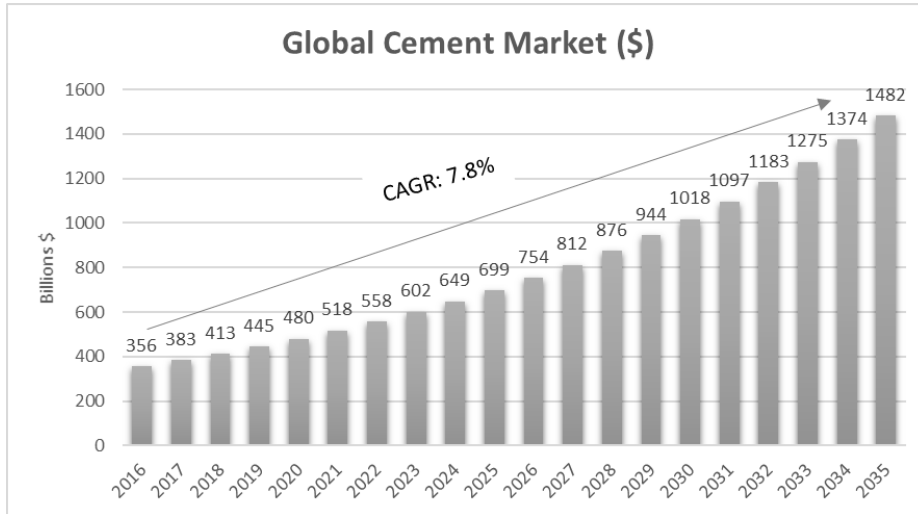

Figure 2. Global Cement Market (Dollars)

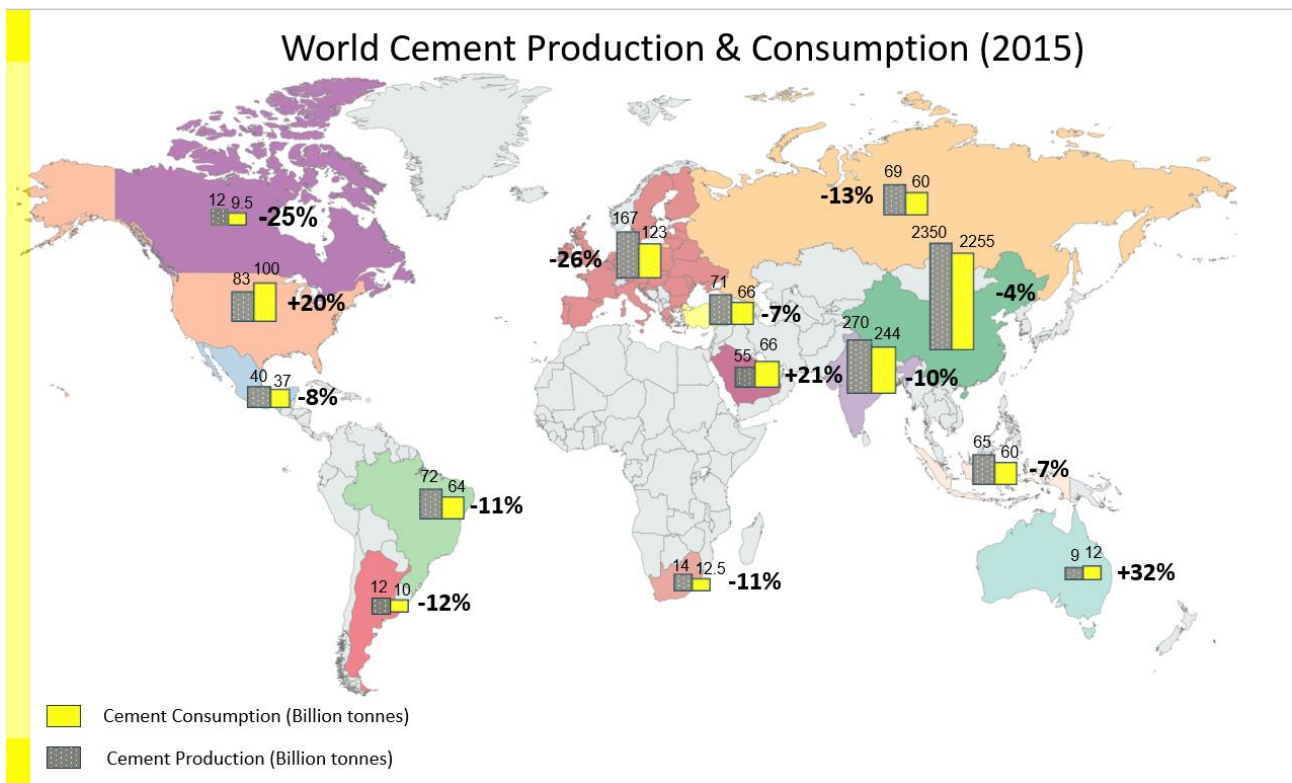

Figure 3. World Cement Production and Consumption



Table 1. World cement consumption and production

Country	Cement Consumption (Million tonnes)	Cement Production (Million tonnes)	Var. %
CHINA	2255	2350	-4
INDIA	244	270	-10
EU28	123	167	-26
USA	100	83	+20
TURKEY	66	71	-7
INDONESIA	60	65	-7
SAUDI ARABIA	66	55	+21
BRAZIL	64	72	-11
RUSSIAN FEDERATION	60	69	-13
MEXICO	37	40	-8
SOUTH AFRICA	12.5	14	-11
CANADA	9.5	12	-25
ARGENTINA	10	12	-12
AUSTRALIA	12	9	+32

5.2.1.2 Europe CEMENT Market Demand

Concrete is the second most consumed material in the world after water. It is no wonder then that the CEMENT INDUSTRY corresponded in 2016 to about 1.9% of the EU 28 GDP. Demand for cement is almost exclusively dependent on activity in the construction sector, either directly through the supply of 'downstream' cement products such as concrete (ready-mixed and pre-cast), mortars and other hydraulic binders.

The European cement market is estimated to reach USD 4,411 million, registering a CAGR of 4.6% from 2018 to 2035.⁷ Moreover, the Western European region is expected to dominate the European market, registering a CAGR of 4.9% from 2018 to 2035, with higher production capacity than consumption.

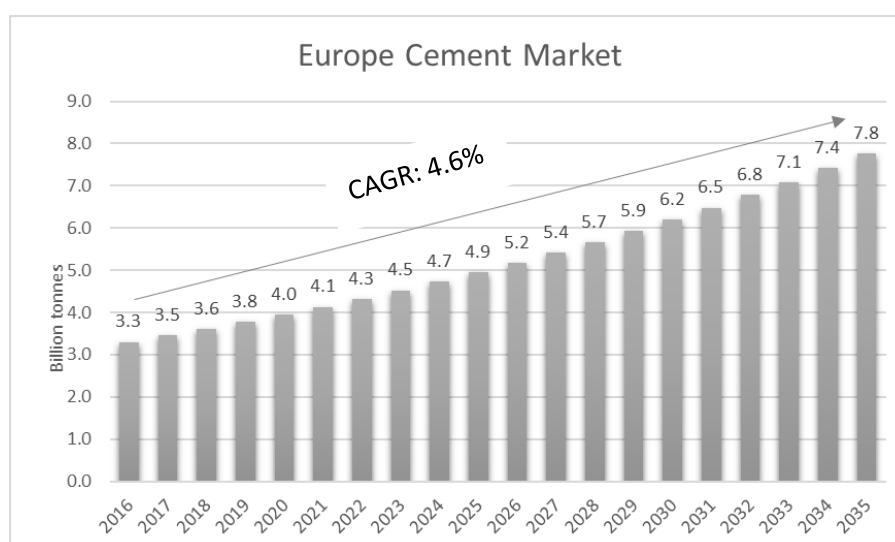

Figure 4. Europe Cement Market (Dollars)

⁷ <https://www.alliedmarketresearch.com/press-release/europe-fiber-cement-market.html>

The diagram below shows the production capacity of all cement plants in Europe compared to actual demand and projected up to 2025 with a CAGR of 2%⁸. As can be seen, there is a strong imbalance between the two figures, which means that the capacity is higher than the actual market demand.

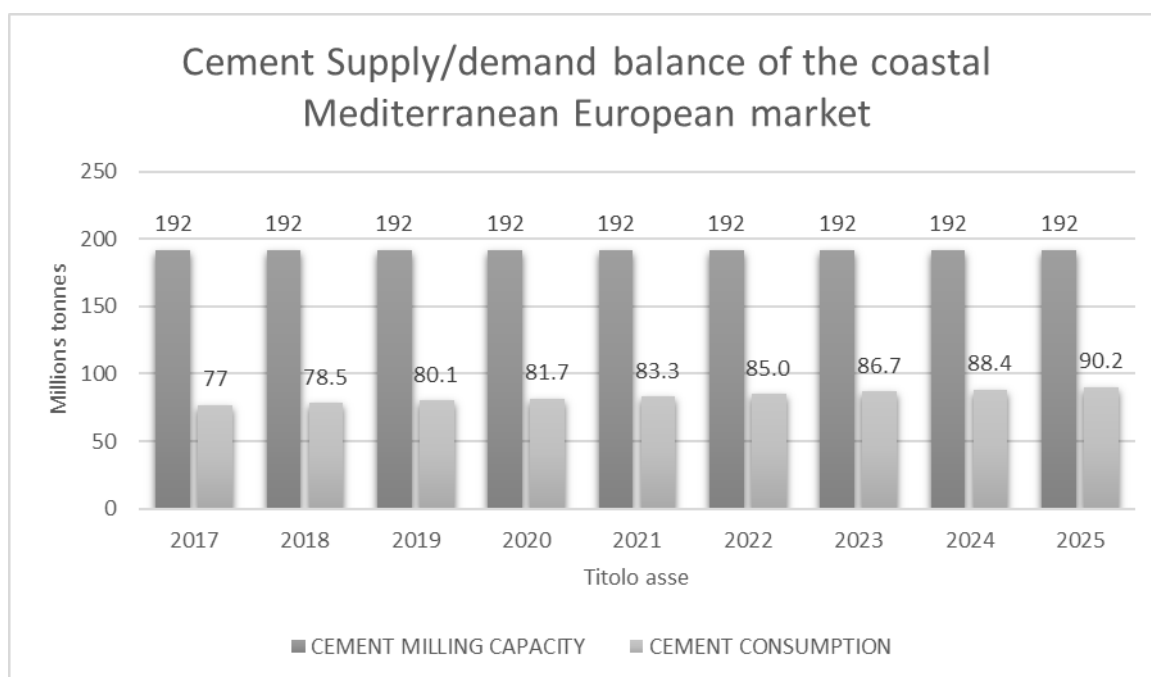

Figure 5. Cement Supply/Demand balance Europe

In Europe between 2015 and 2016 there was a change in cement consumption, the table below shows only the main cement producing countries with the values of tons produced. Only Italy and England show a decrease in production, the first by 2.3 million tonnes, the second by almost one million tonnes. In the following figure, the arrows indicate whether there has been an increase or decrease in consumption.⁹

Table 2. Cement consumption in Europe

CEMENT CONSUMPTION IN EUROPE		
Country	2015 (tons)	2016 (tons)
Austria	2,760,000	2,810,000
France	11,800,000	11,900,000
Germany	22,400,000	22,700,000
Italy	13,900,000	11,600,000
Poland	11,600,000	12,000,000
Spain	12,400,000	12,400,000
United Kingdom	7,800,000	6,850,000

⁸ Source: WORLD CEMENT Manufacturing in the Mediterranean

⁹ <http://www.wbcscement.org/GNR-2016/index.html>



Evolution of Cement Consumption in Europe variation 2015/2016

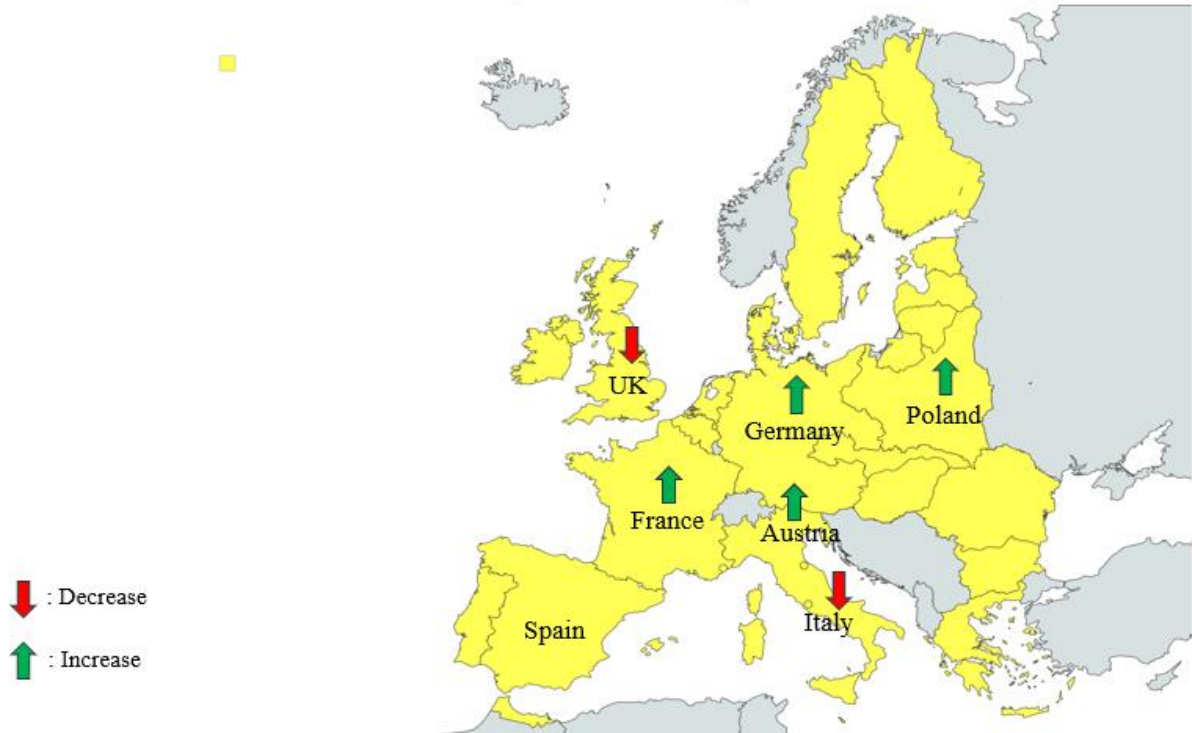

Figure 6. Cement consumption EU

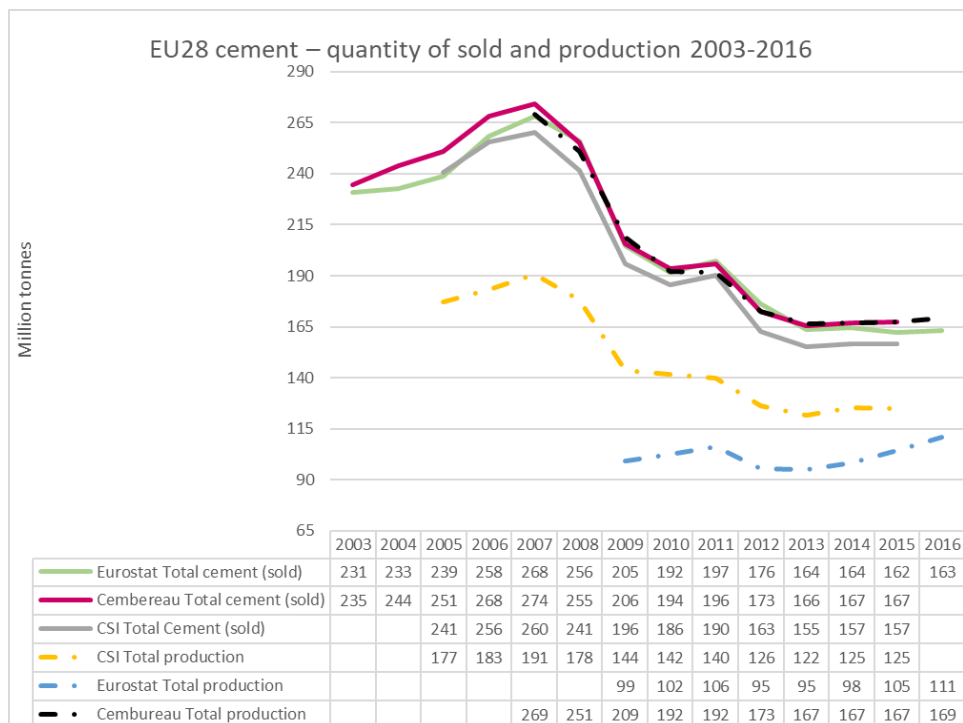

Figure 7. Comparison of cement production and sales data from different sources

5.2.2 CEMENT Industry Key Players

5.2.2.1 Key countries

The data provided by Cembureau from 2001 to 2016 (European Cement Association) on cement production, identify **China as the world's largest producer by far, with 68%**: more than half of the world's cement, followed by India with 8% (5 time less) and Europe with almost 5% (12 time less). **In Europe, Germany leads the largest cement production**, remaining stable in the analysed reference years, followed by Italy with 25% and France with 20.6%.

The following table shows the figures expressed in millions of tonnes in different countries, while in the two following pie charts their percentages are well visible.⁵

Table 3. Cement production in the world

	Cement Production (Million tonnes)									
	2001	2008	2009	2010	2011	2012	2013	2014	2015	2016
CHINA	661	1338.4	1664	1881.9	2063.2	2137	2420	2480	2350	2410
INDIA	102.9	185	205	220	240	270	280	260	270	290
EU28	255.6	250.8	209	192.1	191.6	172.6	166.6	166.8	167.2	169.1
USA	88.9	86.3	63.9	65.2	68.6	74.9	77.4	83	83.4	85.9
TURKEY	30	51.4	54	62.7	63.4	63.9	72.7	71.2	71.4	75.4
INDONESIA	31.1	38.8	36.9	39.5	45.2	32	56	65	65	63
SAUDI ARABIA	20	37.4	37.8	42.5	48	50	57	55	55	61
BRAZIL	39.4	51.6	51.7	59.1	63	68.8	70	72	72	60
RUSSIAN FEDERATION	28.7	53.5	44.3	50.4	56.1	53	72	68.4	69	56
JAPAN	79.5	67.6	59.6	56.6	56.4	51.3	57.4	53.8	55	56
SOUTH KOREA	52	51.7	50.1	47.4	48.2	48	47.3	63.2	63	55
MEXICO	33.2	37.1	35.1	34.5	35.4	35.4	34.6	35	39.8	40.8
GERMANY	32.1	33.6	30.4	29.9	33.5	32.4	31.5	32.1	31.1	32.7
ITALY	39.8	43	36.3	34.4	33.1	26.2	23.1	21.4	20.8	19.3
FRANCE	19.01	21.2	18.1	18	19.04	18	17.5	16.4	15.6	15.9
SOUTH AFRICA	8.4	13.4	11.8	10.9	11.2	13.8	14.9	13.8	14	13.6
CANADA	12.1	13.7	11	12.4	12	12.5	12.1	12.8	12.5	11.9
ARGENTINA	5.5	9.7	9.4	10.4	11.6	10.7	11.9	11.8	12.2	10.9
UNITED KINGDOM	11.9	10.5	7.8	7.9	8.5	7.9	8.5	9.3	9.6	9.4
AUSTRALIA	6.8	9.4	9.2	8.3	8.6	8.8	8.6	9.3	9.3	9.4

Focussing on EU, between 2015 and 2016 France had a demand increase, while Italy a decrease in both consumption and production: figures halved in 15 years (40 to 20 million tons from 2001 to 2016 with more



evident changes in 2009 and 2012). As far as England is concerned, the data are not optimistic because both consumption and production do not suggest a growing development of the cement industry.

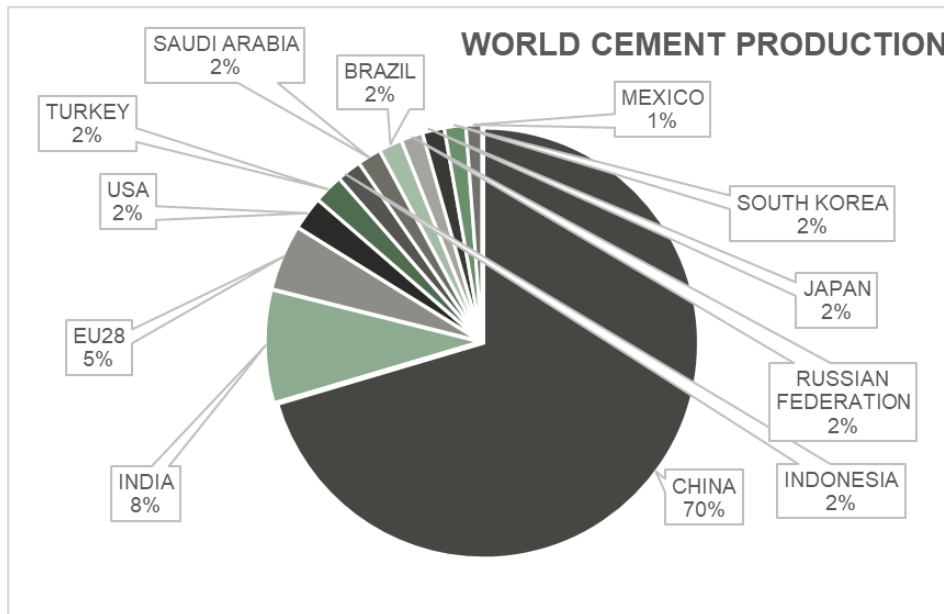

Figure 8. World cement production

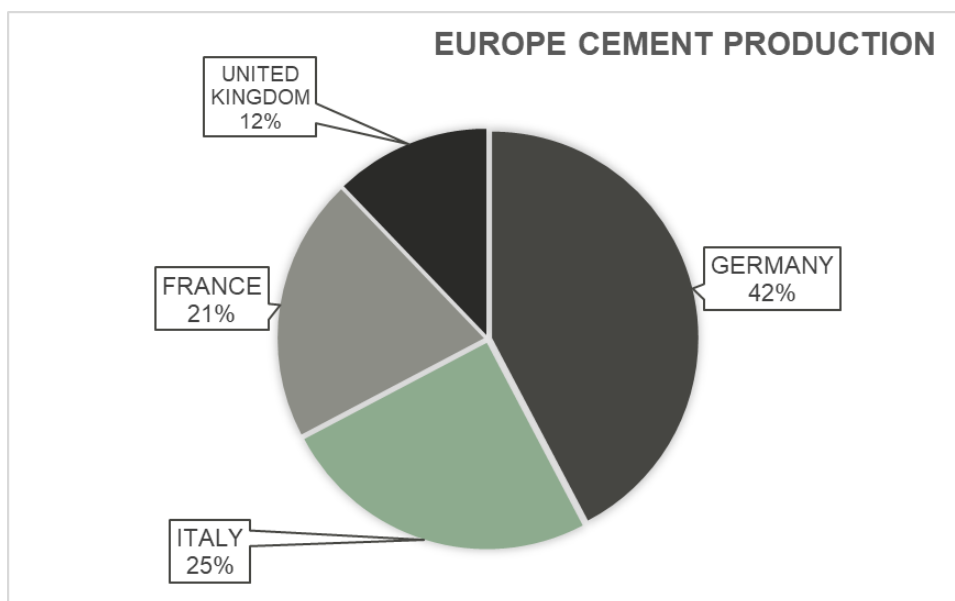

Figure 9. Europe cement relative production between the main producers

5.2.2.2 Key producers

There are ~270 cement production plants in the EU and the sector employs 47,000 people directly.¹⁰ The sector currently aims to build an increasingly consolidated industry at European level, as the main companies develop diversified geographic portfolios as a way of limiting risks and increasing their potential for growth.

As raising the price is not a feasible strategy because cement is perceived as a commodity, the strategies of the large players present in Europe (LafargeHolcim, the HeidelbergCement Group, CEMEX, Buzzi Unicem) include **cost leadership** (systematic and rigorous management of costs, sharing and implementing best practices and a continuous improvement of operational performance), **commercial transformation** (anticipating the needs of customers, early involvement in projects etc.) and the **standardisation of processes** (business processes, technology, and organisational structure across all countries). **Mergers and acquisitions** between the largest companies (e.g. merger of Lafarge and Holcim, HeidelbergCement’s acquisition of Italcementi) form part of a continuous trend.

The main key players in the cement market are¹¹:

Table 4. Main key players market share

Key Players	Market Share
CNBM	20,2%
Lafarge-Holcime	16,8%
Anhui Conch	13,4%
Jidong Development	10,0%
Heidelberg Cement	8,8%
Shanshui	7,8%
Cemex	6,8%
China Resources	5,8%
Taiwan Cement	4,8%
Aditya Birla Group	3,8%

Share of Key Players (%)

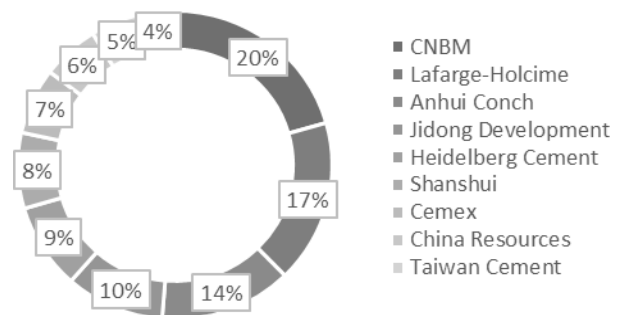

Figure 10. Main world key players

One of the largest cement companies in the world, Germany's *Heidelberg Cement AG* generated around 20,7 billion euros in revenue in the 2017.¹²

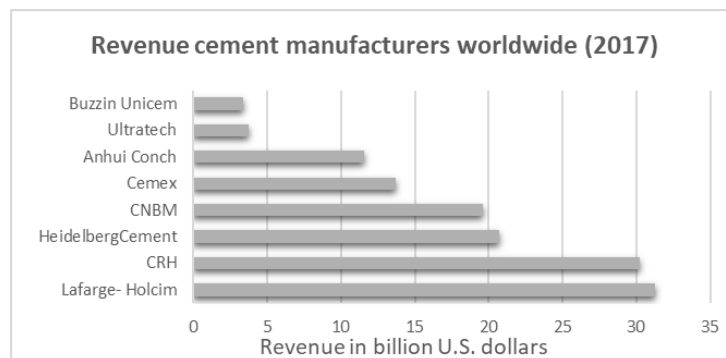

Figure 11. Revenue cement main manufacturers

¹⁰ Zep report, CO₂ Capture and Storage (CCS) in energy-intensive industries, 2013

¹¹ <http://industryreports.over-blog.com/2017/03/global-cement-market>

¹² <https://www.statista.com/statistics/268048/major-cement-manufacturers-worldwide-based-on-revenue/>



Despite a consolidated ownership pattern within the European industry, the continued presence of smaller local/regional companies implies that differences exist in industry structures at national level.

Moreover, due to the low value-to-weight ratio of cement, cement is usually supplied within a close geographical proximity to location of production, typically within a maximum radius of 150 to 250 km. Consequently, cement markets are local and geographically segmented, with competition occurring at a local/regional level. Thus, increased concentration at a European level may not directly result in changes in competition conditions at a local/regional level.

Furthermore, regulations on competition, including those from the European Commission, aimed at protecting cement customers from the negative effects of high concentration and preserving competitive markets, limiting the possibilities for more horizontal integration¹³.

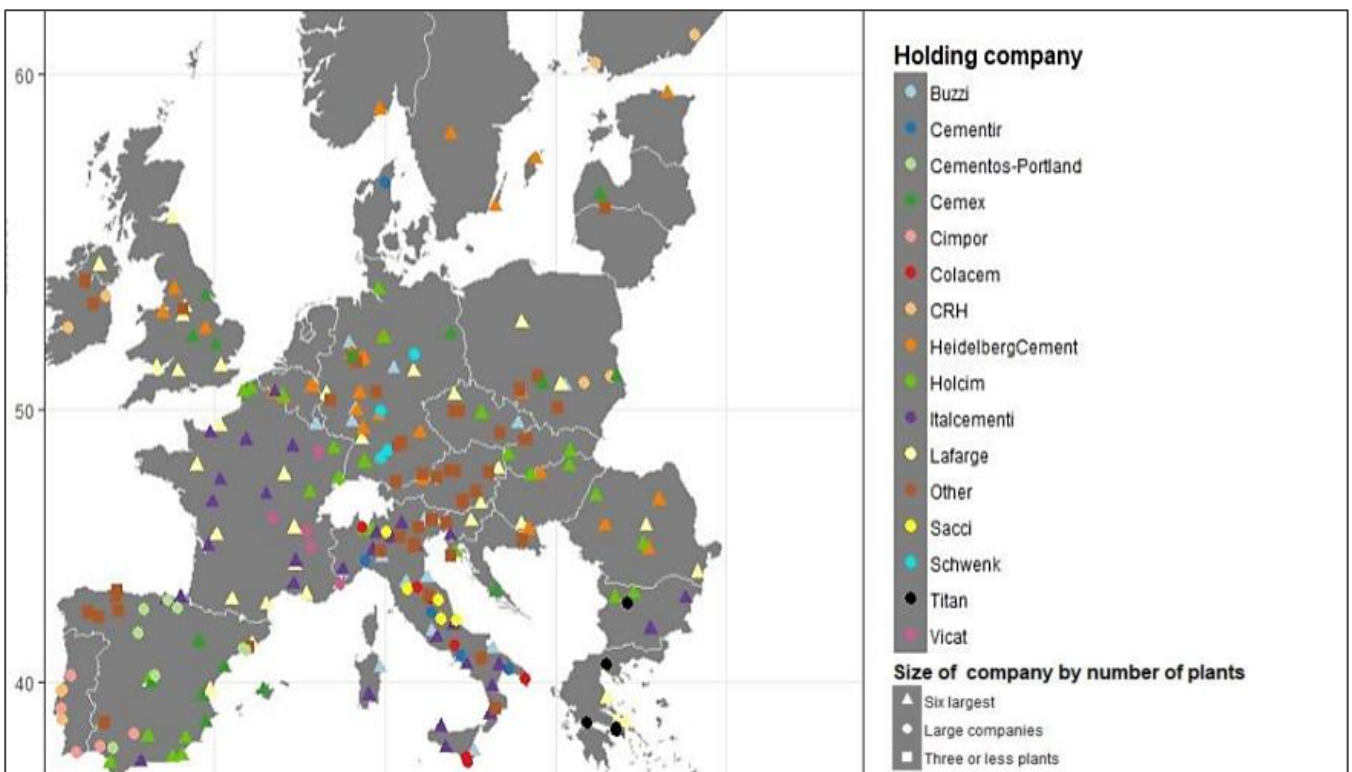

Figure 12. Geographical distribution of cement plants in Europe by holding company

¹³https://www.wifo.ac.at/jart/prj3/wifo/resources/person_dokument/person_dokument.jart?publikationsid=61003&mime_type=application/pdf

5.2.3 CEMENT Industry Sector Description:

5.2.3.1 Employment & global turnover

The Cement Industry contributes significantly to the European economy. According to some sources, it is the second most consumed substance on Earth (after water).

In 2015, the most recent year of available comparative data, the cement manufacturing industry in the EU represented an estimated €15 billion turnover and €4.8 billion in value added and offers employment to 47 thousand persons in the EU in ca. 300 enterprises.

Indirectly, according to a 2015 study by *Le BIPE* for the Concrete Initiative, the combined cement and concrete industry generates a total value added of € 56bn in the EU-28 and generates over 1.1 million jobs.

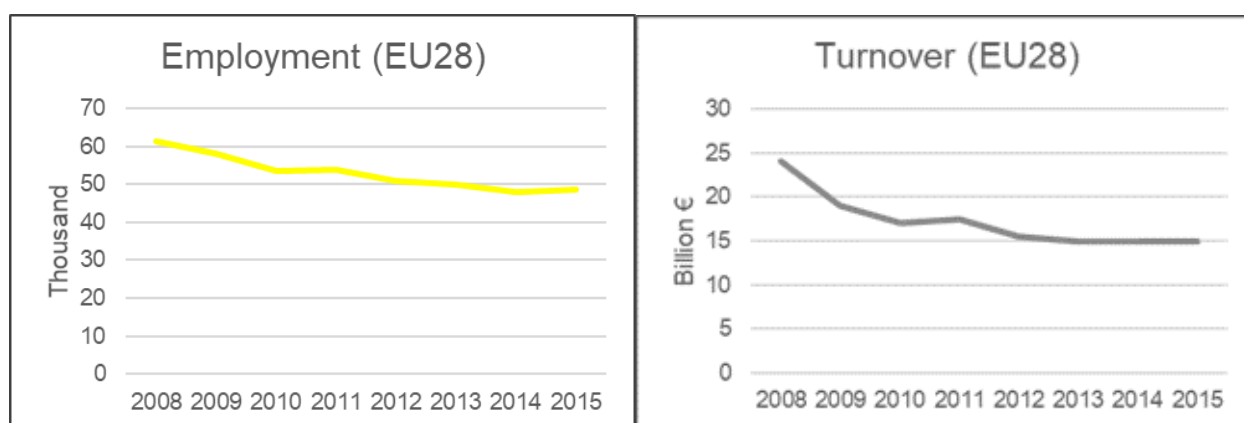

Figure 12. Turnover & Employment

5.2.3.2 Value-Chain

In this section the supply-chain of cement is described starting from the standard production process; its decomposition is useful to analyse relevant topics and criticalities and, further, to better assess DESTINY's impact.

Capital intensity: the cost of cement plants is usually above € 150M per million tonnes of annual capacity (equivalent to around 3 years of turnover), with correspondingly high costs if modifications (e.g. retrofits) are explored. This ranks the cement industry among the most capital-intensive industries.

Transport: land transportation costs are significant, that's why there was a standard threshold beyond a 200 km or at most 300 km distance. In time, bulk shipping has changed that significantly, as now it is cheaper to cross the Atlantic Ocean with 35,000 tonnes of cargo than to truck it 300 km.¹⁴

Energy intensity & High Emissions: Each tonne of cement produced requires 60 to 130 kilogrammes of fuel oil or its equivalent, depending on the cement type and the process used, and about 110 kWh of electricity. Cement is indeed one of the largest emitting industries in the world (8% of CO₂ emissions). Remarkably,

¹⁴ <https://www.coursehero.com/file/p2sfi5fu/An-industry-with-low-labour-intensity-With-the-development-of-modern-automated/>

roughly half of these emissions come from the limestone heating process (direct emissions), while the burning of fossil fuels to heat the kiln indirectly results in the remaining half of CO₂ emissions.

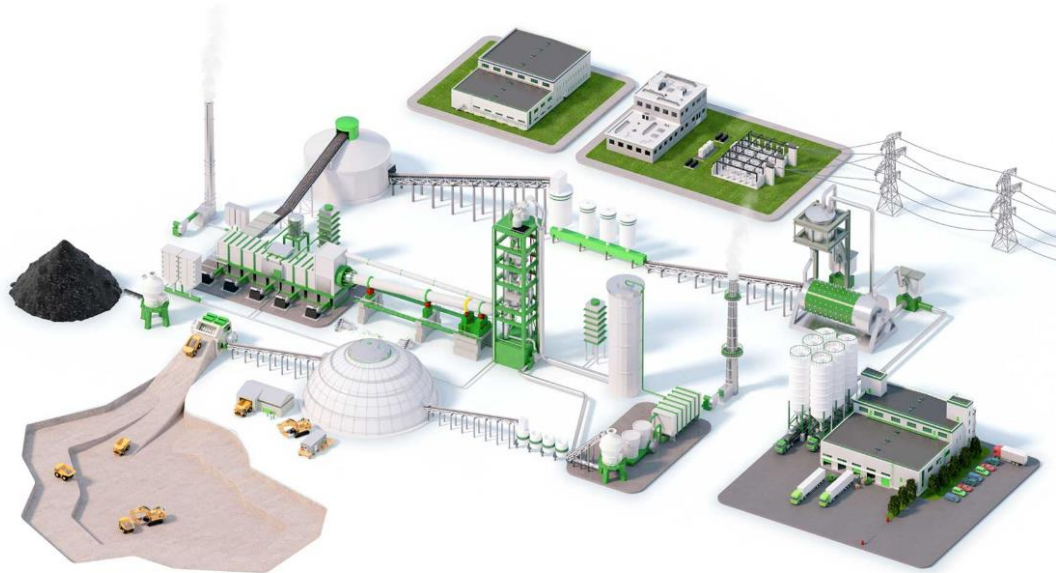

Figure 13. Cement plant overview (source: <https://nikopicto.com/schneider-electric-1>)

The figure below provides a simplified supply chain for cement, from upstream quarrying activities, through cement production, the production of various cement-based downstream production activities and their eventual use, mainly in the construction sector. Often companies integrate the process from quarrying to the different types of cement and cement products and then supply directly the end-user construction sector.

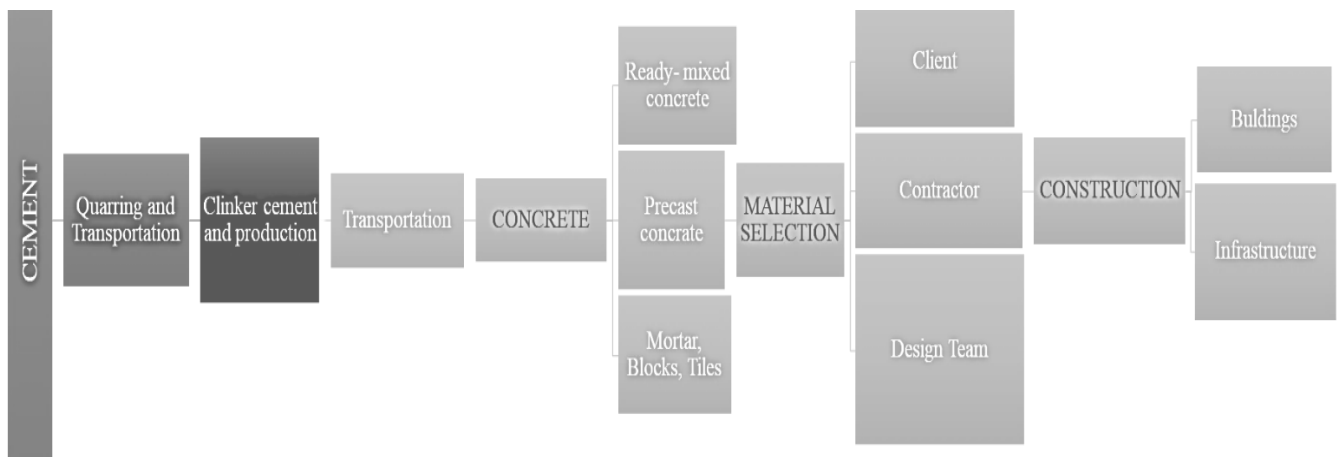

Figure 14. Value Chain

Many, if not most, cement companies show a high degree of vertical integration and are consequently involved throughout the supply chain. The majority of cement companies own the quarries. Some producers also integrate downstream industries (i.e. concrete and aggregates). The extent of this downstream integration varies by country. Vertical integration can be a decisive factor, especially in mature markets. This allows companies to optimise their production process and to ensure high and consistent quality of their products. For producers of white cement, a secure the supply of high-quality limestone is important. Also,

the high level of capital expenditure required for production means that it is important to ensure that plants have the enough supply of raw materials to remain operational for many years.

Table 5. Assessment factors

EFFICIENCY	ACCEPTABILITY	SUSTAINABILITY ISSUES
<ul style="list-style-type: none"> • Location • Innovation • Capacity • Demand Changes • New competition • Price fluctuation • Supply fluctuations • Energy changes • Conservative nature of clients and practitioners • Training in use of alternative materials • Fragmented supply chain and ineffective integration of different actors early on in the planning process 	<ul style="list-style-type: none"> • Project cost • Charging cost • Integration • Defines the scope and budget • Strong link to suppliers • Timescales • Contract structures enforce hierarchies and limit information sharing • Litigious industry environment makes pursuing novel products difficult • Concerns over durability and associated liability and reputational risk • Policy and regulatory limitations to use of novel materials. 	<ul style="list-style-type: none"> • Occupational Healthy and Safety • Biodiversity and Rehabilitation • Noise pollution • Dust Emission • Reduction GHG and other Emissions, • Alternative fuels and Raw Material Use • Energy Efficiency, • Reduction of Natural Resource Use • Water Use • Waste Disposal • Road Traffic Intensity • Local Community Dialogue • Product Information

5.2.3.2.1 Process Routes

There are **four main process routes** for manufacturing cement: the dry process, the semi-dry process, the semi-wet process and the wet process. **As a matter of fact, the choice of the type is largely determined by the state of the available raw materials (dry or wet).**

The trend converges on dry processes. A large part of world clinker production is still based on wet processes. However, in Europe, around 90% of production is based on dry processes thanks to the availability of dry raw materials. Wet processes are more energy-consuming and, thus, more expensive. It can thus be argued that plants using semi-dry processes are likely to switch to dry technologies whenever expansion or major improvement is required, while plants using wet or semi-wet processes normally have access to only moist raw materials.

All these process routes include the same three main activities that can be summarised as: (1) quarrying, (2) preparing/grinding the raw materials, (3) producing the clinker and (4) grinding and blending the clinker with other products to make cement: the biggest differences among processes lay in preparing and grinding the raw materials.

Differently, all processes use rotary kilns for the third stage, despite there are big differences in those kilns: the length of the wet-process kilns ranges from 120 to 180 m, with an internal diameter from around 4.5 to 7 m, whereas in the modern dry technology the length ranges are typically 45 to 75 m, with internal diameters of 3.5 to 4.5 m.¹⁵

Raw material quarrying - The main raw materials needed for the manufacture of cement are limestone and clays, as well as other rocks of intermediate composition (e.g. slate, marls). Limestone provides the needed calcium oxide mainly and some of the other components, while clays provide most of the silica, alumina calcium and iron oxides. The raw materials are extracted from quarries which are mostly open-pit. The cement plants are most usually situated close to the limestone. After extraction, the raw materials are

¹⁵ http://publications.jrc.ec.europa.eu/repository/bitstream/JRC59826/reqno_jrc59826_as_published_jrc59826_jrc-2010-energy_efficiency_and_co2_emissions_prospective_scenarios_for_the_ce%5B1%5D.pdf



crushed, pre-homogenized, ground and proportioned so that the resulting mixture has the desired fineness and chemical composition to be fed in the cement kiln. The power consumption for crushing can range between 0.4 and 1.0 kWh/t of raw material.

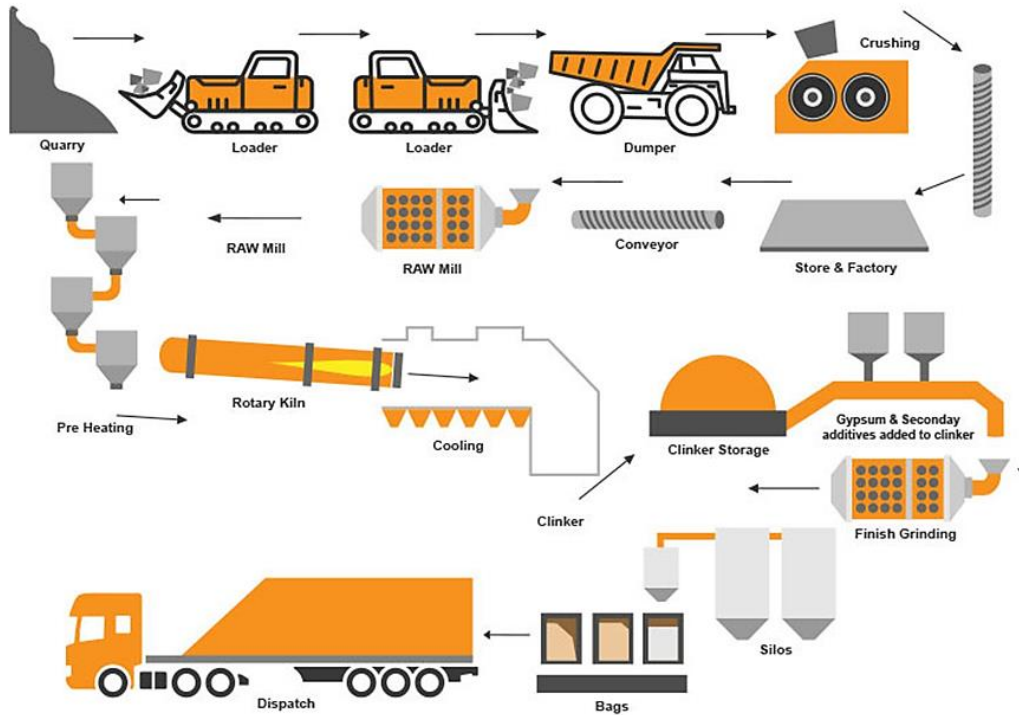
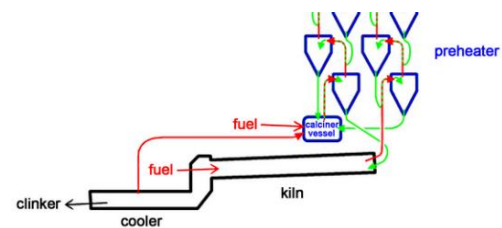

Figure 15. Cement production process

Raw material preparation - After the primary and secondary size reduction, the raw materials are further reduced in size by grinding. There are a variety of grinding technologies used, e.g. ball mills, roller mills and roller presses. The grinding process differs with the type of the kiln used for clinker production. When dry kilns are used, the raw materials are ground into a flowable powder. The typical moisture content of the feed kiln is about 0.5%. When the raw materials have high moisture content (more than 20%) wet kilns are used in clinker production. In the wet process, the raw materials are ground with the addition of water in ball mills to produce a slurry typically containing 36% water. **Raw material grinding is electricity intensive and can consume 9-32 kWh/t raw.**

Clinker burning (pyro-processing) - Clinker production is the most energy-intensive step in cement production, accounting for more than 90% of the total energy use and all the fuel use. Clinker is produced by pyro-processing in cement kilns. Cement kilns evaporate the water present in the raw meal, calcine the carbonate, and lastly, form cement minerals (clinker). The produced clinker is then cooled down in coolers. Clinker is produced with the wet or the dry process. **The dry process has lower energy requirements than the wet process due to the lower evaporation needs.**

Figure 16. Preheat/Precalciner kiln type (source www.cementkilns.co.uk)



To increase the waste heat recovery and thus the overall energy efficiency, dry kilns are equipped with preheater tower systems. The more preheater stages the less energy is consumed, especially when the process is wetter. More recently, the precalciner technology has been developed in which a second combustion chamber is added between the kiln and the pre-heater system that allows for further increased efficiency: **the most efficient pre-heater, pre-calciner kilns use approximately 2.9 GJ/t clinker.**

Cement grinding - To produce Portland cement, the cooled cement clinker is ground together with additions (3-5% gypsum to control the setting properties of the cement) in ball mills, ball mills in combination with roller presses, roller mills, or roller presses (Alsop and Post, 1995). To produce blended cements, cement clinker is ground along with other additives, such as granulated blast furnace slag (GBFS), fly ash, natural or artificial pozzolanas and limestone. In some cases, these additives need to be dried first. The electricity use for cement grinding depends on the surface area required for the final product and the additives used. Electricity use for raw meal and finish grinding depends strongly on the hardness of the material (limestone, clinker, pozzolana extenders) and the desired fineness of the cement as well as the number of additives. Blast furnace slags are harder to grind and hence use more grinding power. The final product, finished cement is then stored in silos, tested and filled into bags, or shipped in bulk on bulk cement trucks, railcars, barges or ships.

Electricity is also consumed for conveyor belts and packing of cement, but the total consumption for these purposes is generally low¹⁶.

5.2.3.2.2 Cement types

Since 1993, the classification of cements has been unified at European level according to the UNI EN 197-1 standard, which establishes compositional and strength requirements.

The products of the family of common cements covered by EN/197-1 are grouped into 5 main types, 27 subtypes and 6 classes of resistance, for a total of 162 (27 × 6) possible types of cement with different characteristics.

Table 6. Type of cement

TYPE	Know as	Composition
Type I (CEM I)	Portland Cement	> 95% clinker
Type II (CEM II)	Portland Composite Cements	65-94% clinker, and 6-35% other constituents
Type III (CEM III)	Blast furnace cements	5-64% clinker, and 36-95% blast-furnace slag
Type IV (CEM IV)	Pozzolanic cements	45-89% clinker, and 11-55% of silica fume or, pozzolana or fly ash or a combination thereof
Type V (CEM V)	Composite cement	(20-64% clinker, and 18-50% blast-furnace slag, and 18-50% pozzolana or siliceous fly ash or a combination thereof

¹⁶ Source: ADVANCE "A Modelling Guide for the Cement Industry" 2016



5.2.3.3 Used Technologies

At the core of the process there are **rotary kilns**. The first ones were long wet kilns, in which the whole thermal process took place. Introducing the dry process, the optimisation led to techniques which allowed drying, preheating and calcining to take place in a stationary installation rather than in the rotary kiln.

The rotary kiln consists of a steel tube with a *length-to-diameter* ratio of between 10:1 and 38:1. The tube is supported by two to seven (or more) support stations, has an inclination of 2.5 to 4.5% and a drive rotates the kiln about its axis at 0.5 to 5.0 revolutions per minute. The combination of the tube's slope and rotation causes material to be transported slowly along it. In order to withstand the very high peak temperatures, the entire rotary kiln is lined with heat resistant bricks (refractories). All long and some short kilns are equipped with internals (chains, crosses, lifters) to improve heat transfer.

The fuel introduced via the main burner produces the main flame with flame temperatures of around 2000°C. For process optimisation reasons, the flame has to be adjustable within certain limits. In a modern indirectly fired burner, the flame is shaped and adjusted by the primary air (10–15% of total combustion air).

Transient build-up of material can occur around the inner surface of the kiln depending on the process and raw materials, etc. These are known as rings and can occur at the feed end (gypsum rings), near the sintering zone (clinker rings) or at the product exit end (ash rings). The latter two types can break away suddenly and cause a surge of hot, poor quality material to leave the kiln, which may then be reprocessed or have to be rejected as waste. The cyclones and grates of preheater kilns may also be subject to the build-up of material which can lead to blockages.

The table below summarizes the different types of kilns with their most important characteristics.^{17,18,19,20} Their electricity demand is about 90 to 150 kWh/t of produced cement. In turn, Figure 17 from the *World Business Council for Sustainable Development (WBCSD)* shows, the clinker production from 1990 to 2016 for each type of kilns described²¹.

While *the most used kiln is the Cyclone*, there is also another type of kiln that has not been shown in the table since it is less and less widespread because it has a production of only 300 tonnes/day and is defined *vertical kiln or shaft kiln*. A few shaft kilns are used for cement production in Europe. Kilns of this type consist of a refractory-lined, vertical cylinder 2–3 m in diameter and 8–10 m high.

Table 7. Kiln technical characteristics

KILN	Length	Temperature	L/D ratio	Invention date	Process	Production	fuel consumption	Exit gas N/m ³ clinker
Long rotary kiln	200 m	2000°C	38/1	1885	All	3600 t/day	4.60(dry)-5.86(wet)	1.8(dry)-3.4(wet)
Pre-heater grill (Lepol)	<200 m	1000-1100°C	10/1; 17/1	1928	semi-dry	3300 t/day	3.3 MJ/kg	2
Pre-heater in suspension (Cyclone)	< 200 m	850°	13/1; 16;1	1930	Dry	3000 t/day	3.2-3.5 MJ/kg	1.5

¹⁷http://publications.jrc.ec.europa.eu/repository/bitstream/JRC59826/regno_jrc59826_as_published_jrc59826_jrc-2010-energy_efficiency_and_co2_emissions_prospective_scenarios_for_the_ce%5B1%5D.pdf

¹⁸ http://eippcb.jrc.ec.europa.eu/reference/BREF/CLM_30042013_DEF.pdf

¹⁹ <https://www.cementequipment.org/home/kiln-and-cooler/types-rotary-kilns>

²⁰https://www.researchgate.net/figure/Specific-thermal-energy-consumption-in-different-kiln-process-25_tbl2_257726716

²¹ http://www.wbcscement.org/GNR-2016/EU28/GNR-Indicator_8TGK-EU28.html



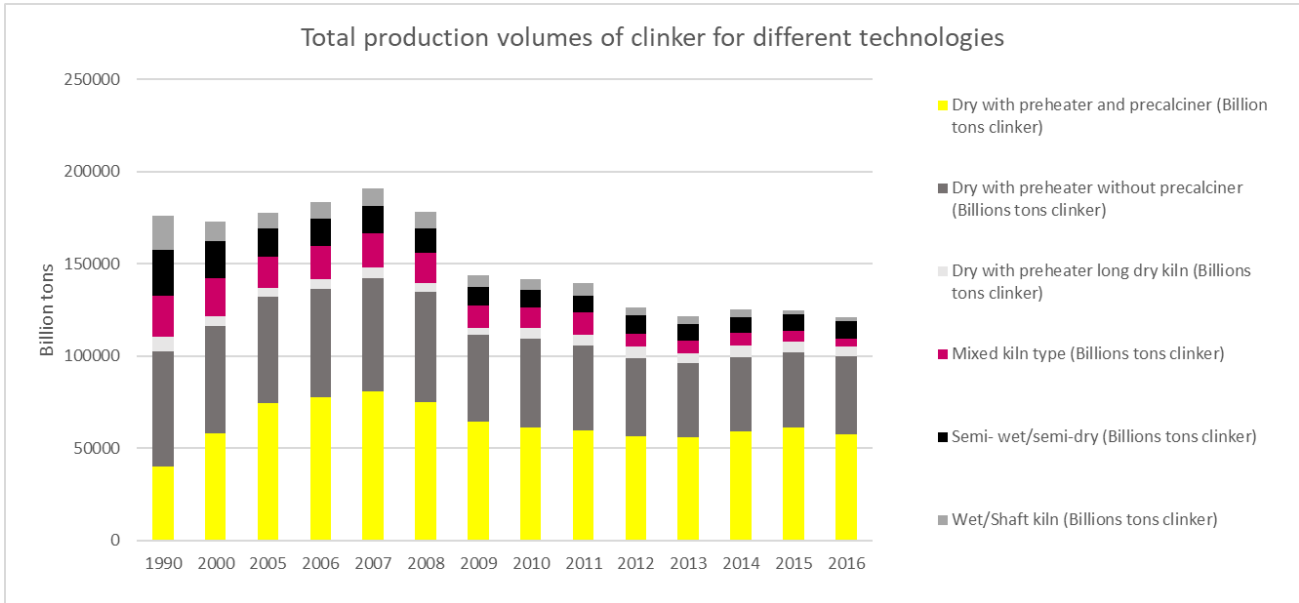

Figure 17. Total production of clinker for different kilns

Technology Insight^{17,18,19,20}

The long-wet process kiln, with a length to diameter ratio (L/D) of up to 40, was the main clinker producing plant for most of the 20th century. It is a relatively simple process, with the main advantage of slurry preparation being the ease of milling, handling, blending, storage, pumping, and metering. It is also less prone to low level dust emission. In wet process systems, the material preheat system is metal chains hanging in the cold end of the kiln, which absorb heat from gases and heat the material which flows over them. The chain actually provides a greater surface area for contact between hot gases and the material clinging to the chains. The main problem with long wet kilns is their poor fuel efficiency, because of the water to be evaporated from the slurry. This became a severe problem only when the cost of fuel escalated during the 1970s, and only a few wet kilns have been built since that time.

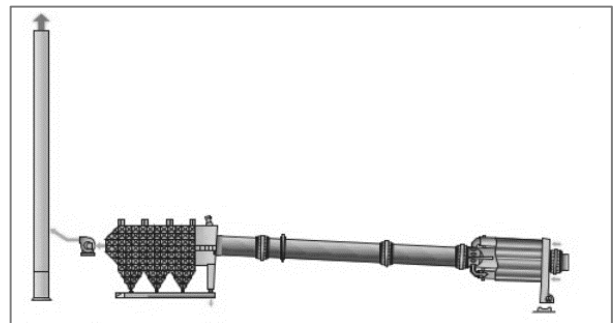

Figure 19. Long wet process kiln

Long Dry Kilns Dimensionally, long dry kilns are similar to long wet kilns. These kilns were developed and became popular particularly in North America. Kiln production rates for long dry kilns are marginally higher than long wet kilns. Their advantage over wet kilns is a potentially improved fuel consumption because the kiln feed is dry. However, kiln exit temperatures of 700°C or more meant that water spray cooling was required, and very little advantage was realized over wet process.

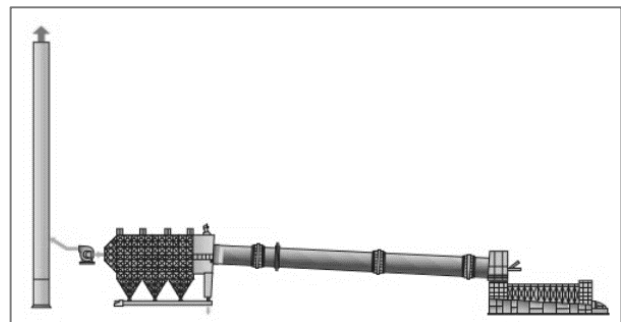

Figure 18. Long Dry Kiln

At a later stage of development, kiln internals included kiln chains (similar to wet kilns), kiln metallic crosses, and ceramic



heat exchangers. The crosses and ceramic heat exchangers basically split the kiln into 3 or 4 cross-sectional areas over about 15 to 20 m, splitting both the feed and gas flow, and providing improved heat transfer. With these enhancements, the kiln gas exit temperatures were reduced to 350°C – 400°C, specific fuel consumption improved some 30% and output increased by 35% to 40% compared to wet kilns.

Pre-heater Kilns

The **Lepol kiln** was invented in 1928 by Otto Lellep and marketed by Polysius, whose names combination led to “Lepol.”

It was a major improvement in kiln thermal efficiency, some 50% over the popular wet kiln process at the time. The technology reached the stage of 3000 tonne/day, with specific fuel consumption of 3.3 MJ/kg (800 kcal/kg). These kilns have a short rotary kiln section, L/D of 12 to 15, preceded by a travelling grate covered by a 150 mm to 200 mm layer of nodulized raw meal. The kiln exits gases at 1000°C or so pass through this nodule layer providing preheat of material before it enters the rotary kiln at about 800°C. The gases exit the grate section at around 100°C, implying very efficient recovery of heat. For some grate preheater kiln systems, the kiln feed nodules experience two separate passes of the hot gases, the first for drying and the second for preheating and partial calcination.

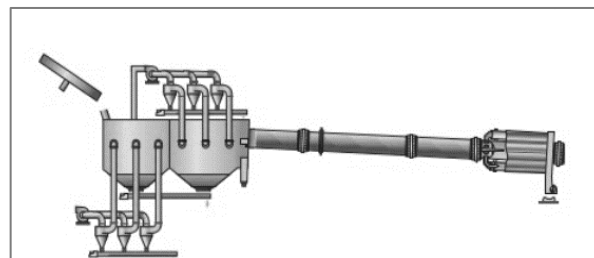

Figure 21. Lepol Kiln

Cyclone pre-heater kiln - the cyclone preheater was first patented in 1934 in Czechoslovakia by an employee of F. L. Smidth. However, the first preheater kiln was built and commissioned in 1951 by KHD. This system utilizes cyclone separators as the means for promoting heat exchange between the hot kiln exit gases at 1000°C and the incoming dry raw meal feed. Cyclone preheater kilns can have any number of stages between 1 and 6, with increasing fuel efficiency with more cyclone preheaters. The most common is the 4-stage suspension preheater, where gases typically leave the preheater system at around 350°C. The rotary kiln is relatively short, with L/D typically 15. The material entering the rotary kiln section is already at around 800°C and partly calcined (20% to 30%) with some of the clinkering reactions already started. Cyclone preheater kiln. Material residence time in the preheater is in the order of 30 seconds and in the kiln about 30 minutes. Preheater pressure drops range from 300 mm to 600 mm water, with gas duct velocities typically 20 m/s in the preheater and cyclones²².

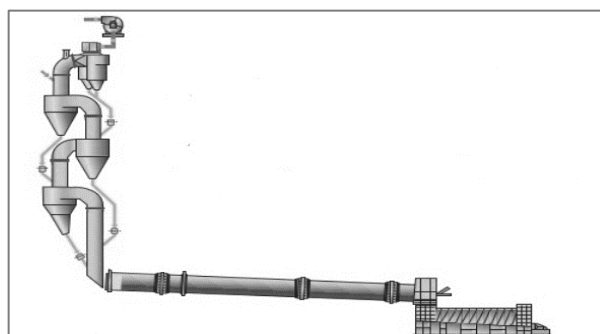

Figure 22 – cyclone preheater

²² <https://www.slideshare.net/maxfactorstorm/111658903-kilnburningsystems>

5.2.4 CEMENT Industry Externalities (completing a PESTLE analysis)

5.2.4.1 Environmental and Societal Impacts

It is acknowledged that cement industry should combine financial performance with a commitment to social responsibility, increasing its Sustainable Development (SD). The current SD profile of cement production can be summarized as follows:

- On the one hand, cement production raises a number of sustainability concerns. It consumes large amounts of energy and resources, emits dust and other pollutants, disturbs large tracts of land during quarrying, and generates greenhouse gases.
- On the other hand, the cement industry contributes to society by providing one of the most relevant commodities for infrastructure and multiple sectors.

A number of leading cement companies already have begun to demonstrate that they can improve their business even through the integration of SD. For example, environmentally friendly practices, such as use of wastes as raw materials and improvement in energy efficiency, can contribute to reduce operating costs, while open engagement with local communities and other stakeholders to support better quality of life can lead to improved company image and right to operate, which ultimately lead to strategic advantages.

As a summary, the cement industry situation is comparable to that of other industries that rely heavily on resource extraction and energy consumption: despite many points of excellence, the sector is not yet fully contributing toward sustainability in the regions where it operates. Further, while environmental performance is in the spotlight, stakeholders have also expressed concern about social and economic performances (for example, cement has recently had the exemption from ETS – Emission Trading System - auctions to avoid the so called *carbon leakage*, namely the moving of production sites out of Europe).

At a minimum, cement companies will need to address their vulnerabilities, but the cement industry has some unique opportunities to capitalize on its strengths in the area of industrial ecology, which involves exchanging resources with other industries to mutual benefit.

The following graphics summarizes the important issues confronting the cement industry. Eight key issues have been identified, defining a PESTLE analysis, which represent the main areas in which the cement industry can contribute to SD.²³

²³https://www.aitecweb.com/Portals/1/Repository/Pubblico/Area%20Tecnica/Pubblicazioni/Toward_a_Sustainable_Cement_Industry.pdf?ver=2018-06-19-120110-210



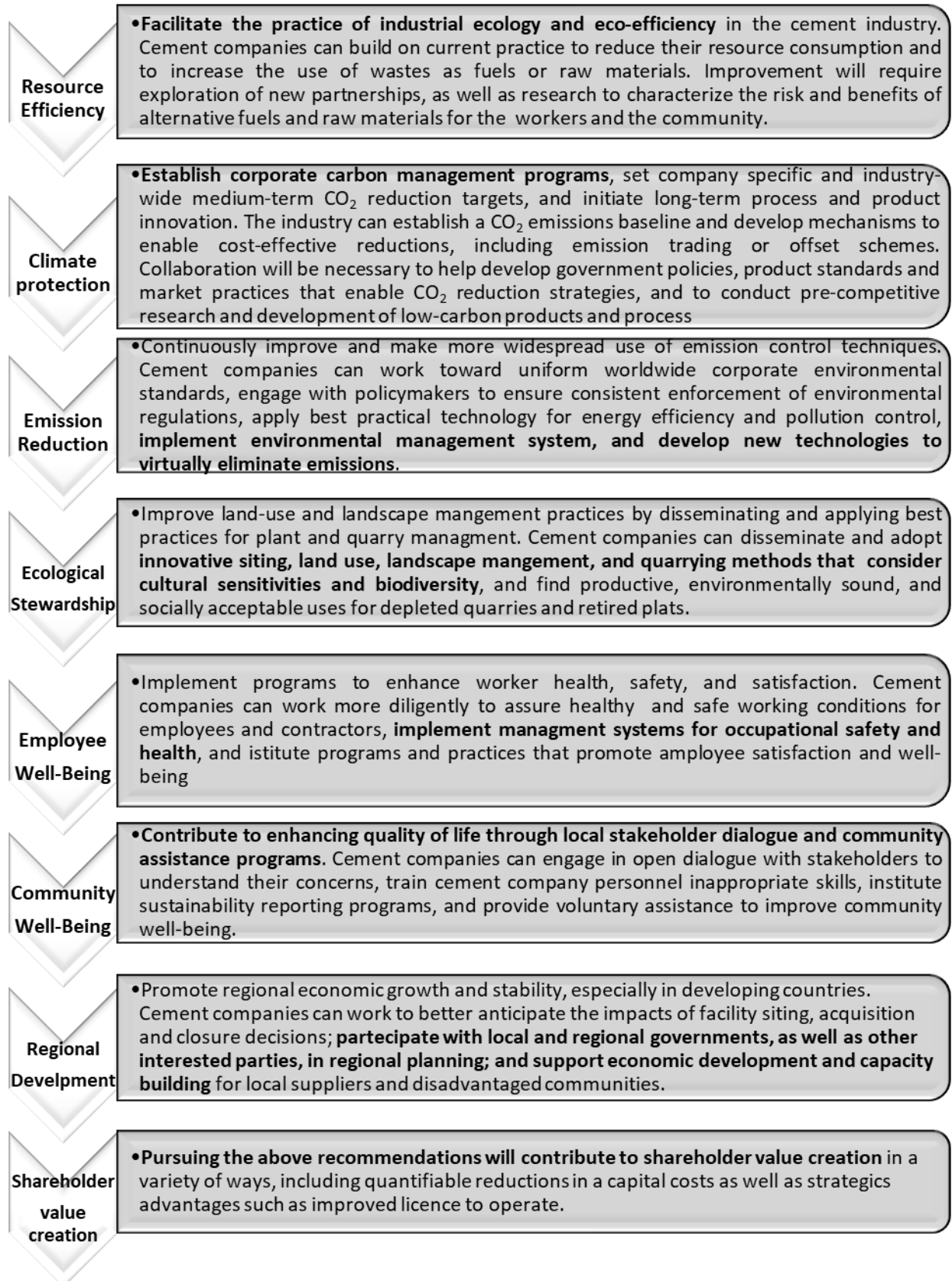

The cement industry has pursued strategies to reduce CO₂ emissions since the 1990s. In particular, **the major producers have worked together under the Cement Sustainability Initiative (CSI)**, and have devoted substantial effort to introducing mitigation solutions. Globally, cement production produces 600-700kg of CO₂ per tonne of cement and this is both because it needs energy (both fuel and electricity) and the production process releases CO₂. There is no single choice or technology capable of lead to a reduction in emissions. Only one combination of different ways to reduce emissions, can achieve substantial reductions²⁴.

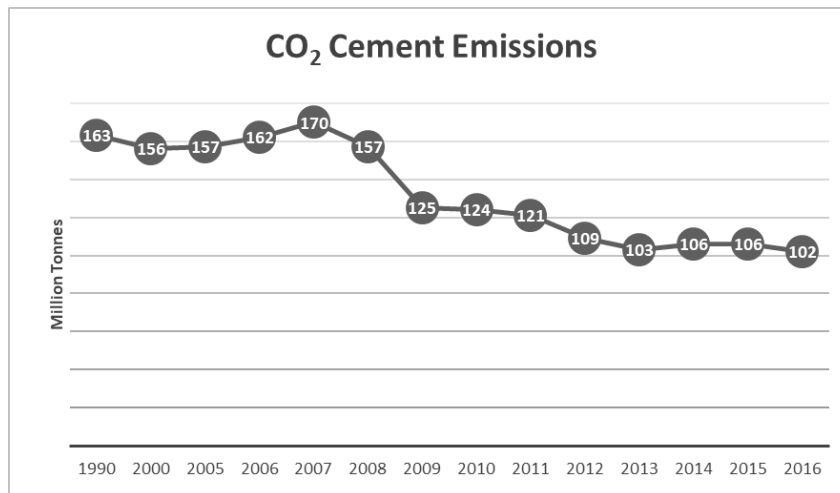

Figure 19. Cement CO₂ emissions in EU^{25,26}

CO₂ emissions vary by kiln type and clinker heating process. The *Cement Sustainability Initiative* provides these emission data and is shown in the following diagram from 1990 to 2016. The dry process with Lepol kiln is the one that has produced the most CO₂ in several years, but this is an obvious fact as it is the most used technology. The process wet with long kiln also has a high CO₂ value but in this case this figure depends on the type of kiln and not on the quantity of production.

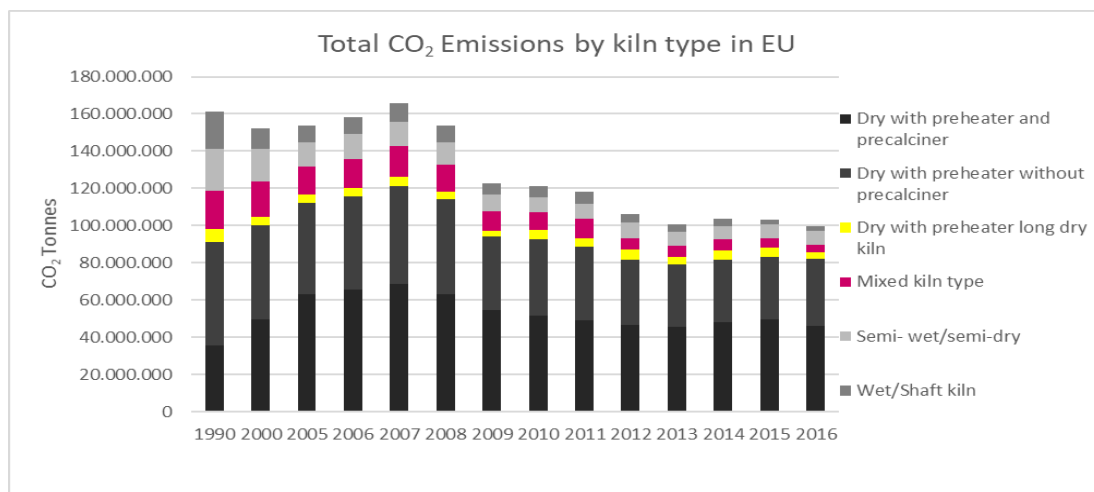

Figure 20. Total CO₂ emissions by kiln type

²⁴<https://reader.chathamhouse.org/making-concrete-change-innovation-low-carbon-cement-and-concrete#introduction>

²⁵<https://ourworldindata.org/co2-and-other-greenhouse-gas-emissions>

²⁶<https://ourworldindata.org/co2-and-other-greenhouse-gas-emissions>



5.2.4.2 Relevant Policies, Standards and Directives

Best Available Techniques (BAT)

Best Available Techniques, BATs²⁷, are adopted in industry to comply with existing regulations, to improve environmental records and often for economic reasons as well.

The BAT general content for the Cement Industry includes:

- ⇒ Identification of key environmental issues: **Energy use and emissions on air** (i.e. NO_x, SO₂ and Dust);
- ⇒ Examination of the techniques most relevant to address those key issues;
- ⇒ Identification of the best environmental performance levels, based on the available data in the EU and world-wide;
- ⇒ Examination of the conditions under which these performance levels were achieved (i.e. costs, cross-media effects, main driving forces involved in implementation of this techniques);
- ⇒ Selection of BAT and associated emission and/or consumption levels in according to Art. 2(11) and Annex IV of the Council Directive 96/61/EC on Integrated Pollution Prevention and Control (IPPC).

General Primary Measures

The BAT for the manufacturing of cement includes the following general primary measures:

- A smooth and **stable kiln process**, operating close to the process parameter set points, is beneficial for all kiln emissions as well as the energy use, by applying:
- **Process control optimization**, including computer-based automatic control systems and use of modern, gravimetric solid fuel feed systems.

Minimising fuel energy use by means of:

- **Preheating and precalcination** to the extent possible, considering the existing kiln system configuration;
- The use of modern clinker coolers enabling **maximum heat recovery**;
- Heat recovery from waste gas.

Minimising electrical energy use by means of:

- **Power management** systems;
- Grinding equipment and other electricity-based equipment with **high energy efficiency**.

Careful selection and control of substances entering the kiln can reduce emissions:

- when practicable selection of raw materials and fuels with low contents of sulphur, nitrogen, chlorine, metals and volatile organic compounds.

The following table²⁸ shows the regulatory limits for the main emissions in the cement industry, according to the BAT emission levels

²⁷ <http://www.isprambiente.gov.it/contentfiles/00001600/1697-m1-u3.pdf>

²⁸ <https://eur-lex.europa.eu/legal-content/IT/TXT/PDF/?uri=CELEX:32013D0163&from=EN>



Table 8. BAT emission level

Emissions source	BAT-associated emission level (mg/Nm ³)							Energy Consumption GJ/t of product
	Dust		Hg	SO ₂	NO _x	CO	COT	
	HCL	HF						
Kilns with preheater	<10	<1	< 0.05	<50- 200	<200-450	<500	<10	5.1-7.8
Long rotary kilns	<10	<1	< 0.05	<50- 400	100-350	<500	<10	6.0-9.2

By adopting BATs it is possible to have an important percentage of fuel and energy reduction. The histogram shows the potential savings of fuel and energy in percentages for each country.

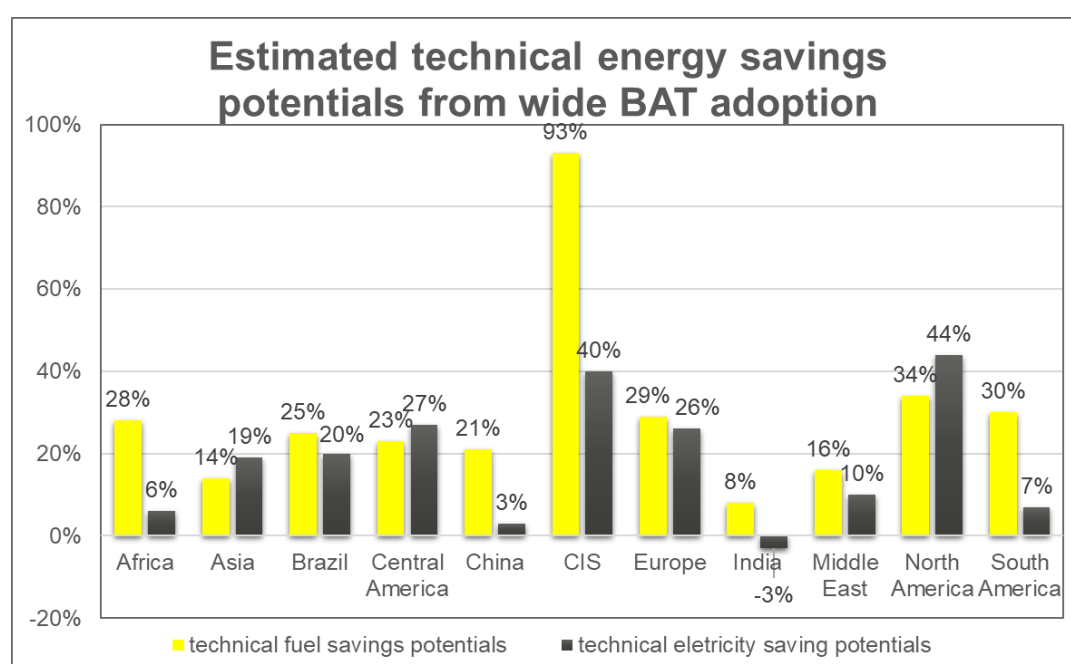

Figure 21. Potential energy saving Source: ADVANCE-WP2 "A model guide for cement industry"

5.2.4.3 Innovation trends in the sector

Emission reduction is a key factor for the cement industry. Further, best practices in emissions reduction can be related to increased efficiency and thus to a better business. Four main levers have been identified to help reduce cement footprint

Thermal and electric efficiency - The first lever involves upgrading kilns and equipment so that less energy is needed to produce cement. Changing plant design, shifting towards higher-efficiency dry kilns, upgrading motors and mills, and using variable-speed drives can make a big difference to energy consumption and costs. Optimizing the recovery of waste heat has been shown to reduce cement factories' operating costs by between 10% and 15%.

Alternative fuel use - The second lever consists of switching from fossil fuels to alternatives such as biomass and waste. Coal has been the main fuel used historically, but cement kilns can safely burn biomass and waste



instead of fossil fuels as the high processing temperature and the presence of limestone clean the gases released, The type of alternative fuel used, however, depends on local availability and the quality of alternatives, which are often outside the control of cement producers. The use of alternative fuels in cement production is most prevalent in Europe, making up around 43% of fuel consumption there compared to 15% in North America, 8% in China, South Korea and Japan, and around 3% in India. This indicates that a lot can still be achieved by simply increasing the use of alternative fuels, particularly in emerging markets such as China and India. There is still room for improvement in Europe, where the average cement plant could substitute around 60% of its fuel with alternatives.

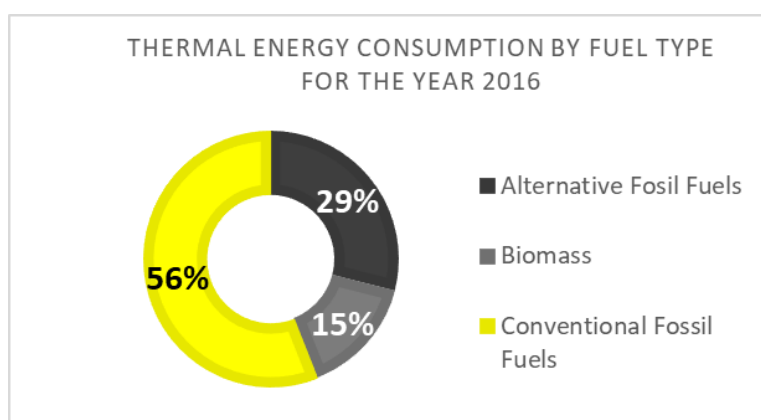

Figure 22. Thermal energy consumption by fuel type²⁹

Clinker substitution - The third lever consists of reducing the amount of Portland clinker used by substituting it with clinker substitutes such as fly ash, GBFS and limestone. The IEA estimates that around 3.7 GJ and 0.83 tonnes of CO₂ can be saved per tonne of clinker displaced. To date, clinker substitution has contributed on average to a 20–30% decrease in CO₂ emissions per tonne of cement produced, compared to the 1980s. While the reduction in clinker use has been substantial, clinker ratios have recently levelled off and there is still considerable scope for improvement in most regions. The main constraints on clinker substitution tend to be the availability and cost of clinker substitute materials, which vary considerably by region, consumer acceptance and the barriers imposed by standards and regulations.

Carbon capture and storage (CCS) - The fourth lever consists of capturing the emissions from a cement kiln, and then securing and storing it. CCS is particularly attractive for cement producers, as the process emissions from heating limestone to produce clinker cannot be avoided by simply switching fuels and improving energy efficiency. Even with large-scale substitution of Portland clinker, emissions from the portion of clinker that would still be produced would continue to present a challenge. CCS accounts for 56% of the planned direct emissions reduction to 2050, compared with 10% for clinker substitution, 24% for alternative fuels and 10% for energy efficiency, the cement industry has engaged in several projects to develop CCS, however, as in other sectors, development has been slow and there are still many barriers which are technological, political, regulatory and public acceptance. One of the main barriers so far has been cost, several countries also lack an adequate legal framework for CO₂ storage and there are currently only two cross-country large-scale storage projects in EU. Finally, the lack of geographic clustering and economy of scale is a problem: most cement plants are too small to justify by themselves the construction of the necessary distribution infrastructure for captured CO₂.

²⁹<https://betoni.com/wp-content/uploads/2018/11/11.-Cement-and-Concrete-in-a-Low-Carbon-Economy-Chief-Executive-Koen-Coppenholle-CEMBUREAU-%E2%80%93-The-European-Cement-Association.pdf>

These levers – excluding CCS – have delivered an 18% reduction in the global average CO₂ intensity of cement production since 1990. Until 2050 a total reduction of 32% with respect to 1990 is expected, while with innovative technologies such as Carbon capture, Carbon re-use, Clinker substitution/Lower Carbon Cements, New binders/ Novel Cements, Product durability, emission reductions of up to 80% could be possible.

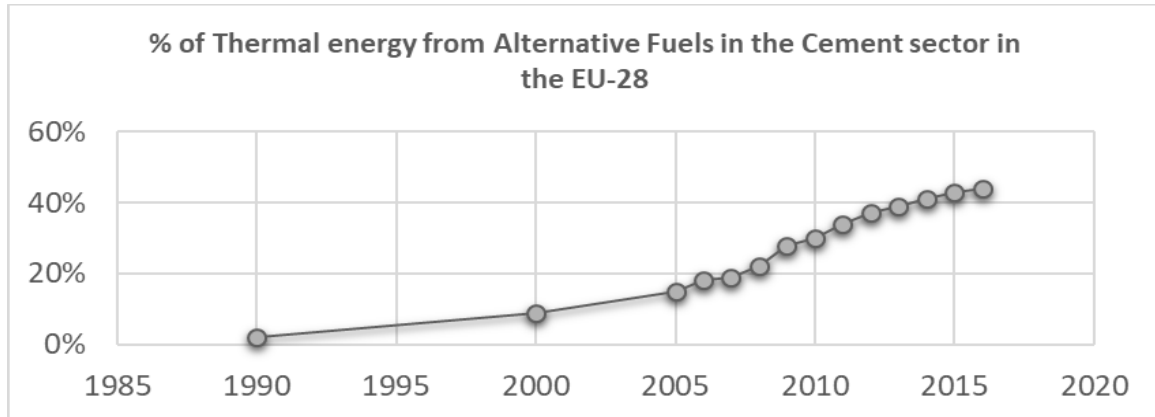

Figure 23. Percentage of alternative fuels³⁰

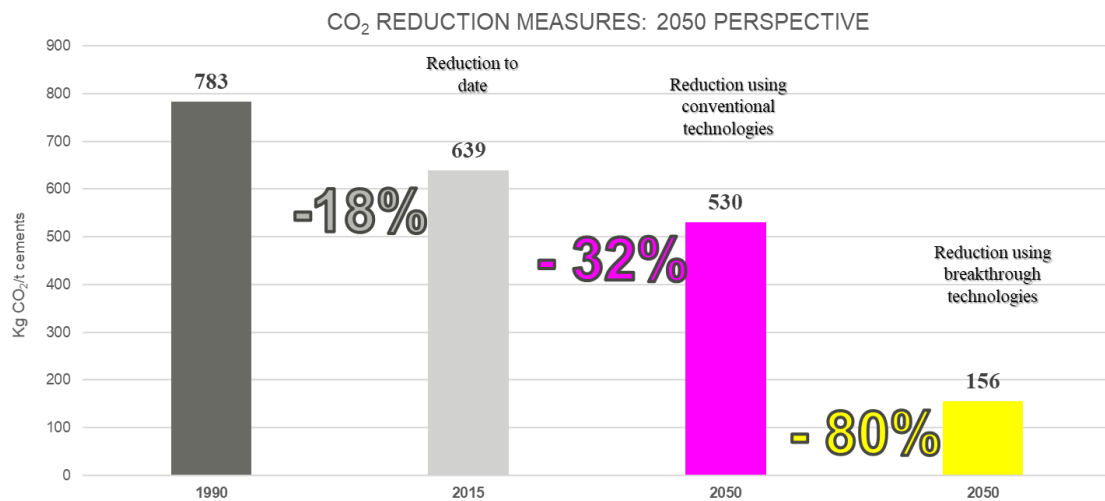

Figure 24. 2050 perspectives through different technologies adoption.³⁰

Case-study: Figure 25Figure 23 shows the emission intensity among major cement manufacturers. Lafarge-Holcim, as leads with higher productions and lower emissions. Among the reasons there is an innovative binder, developed in cooperation with **Solidia Technologies**,^{31,32} a cement and concrete technology company offering patented processes that ease production, reduce costs, and improve performance of cement and concrete, while reducing the carbon footprint of concrete up to 70% and water use up to 100% during manufacturing.

³⁰ <https://betoni.com/wp-content/uploads/2018/11/11.-Cement-and-Concrete-in-a-Low-Carbon-Economy-Chief-Executive-Koen-Coppenholle-CEMBUREAU-%E2%80%93-The-European-Cement-Association.pdf>

³¹ <https://solidiatech.com/>

³² Source: Cembureau "INNOVATION IN THE CEMENT INDUSTRY"



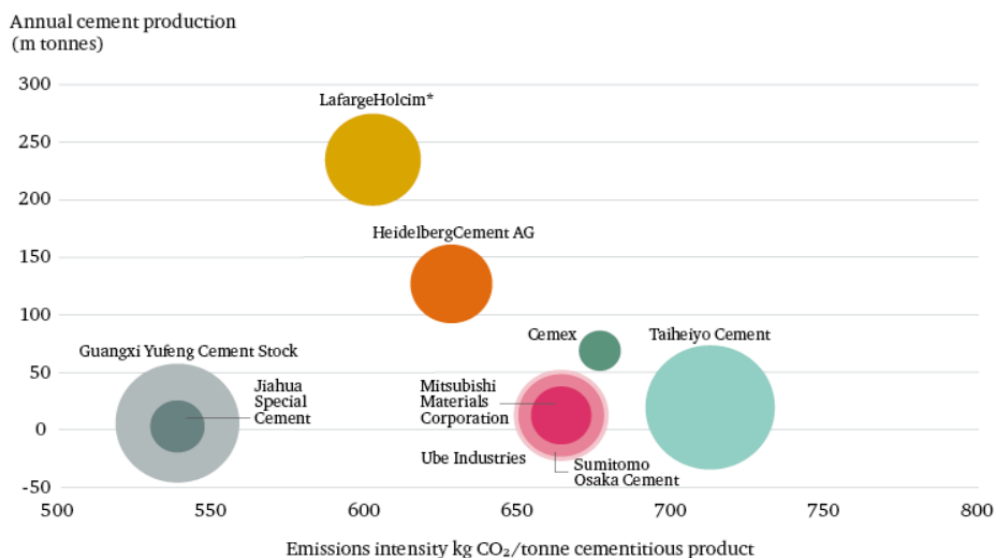

Figure 25. Cement producers: top assignees by production volume and emissions intensity

(Source: Production and emissions intensity data for LafargeHolcim, HeidelbergCement and Cemex, and emissions intensity data for Taiheiyu from Kisić, M., Ferguson, C., Clarke, C. and Smyth, J. (2018), Building Pressure: Which companies will be left behind in the low-carbon transition? CDP Report, http://b8f65cb373b1b7b15feb-c70d8ead6ced550b4d987d7c03fcdd1d.r81.cf3.rackcdn.com/cms/reports/documents/000/003/277/original/Cement_Report_Ex_Summary.pdf?1523261813 (accessed 27 Apr. 2018))



5.3 STEEL SECTOR ANALYSIS



5.3.1 STEEL Market Demand and Supply Analysis

The STEEL INDUSTRY is the second biggest industry in the world after oil and gas with an estimated global turnover of 900 billion USD.³³ The World Steel Association forecasts the global steel production³⁴ will reach 1,772 Mt at the end of 2019 and the global steel demand³⁵ will reach 1,735 Mt in the same year (with an increase of 1.3% over 2018). In 2020, the demand is projected to grow by 1.0% to reach 1,752 Mt.

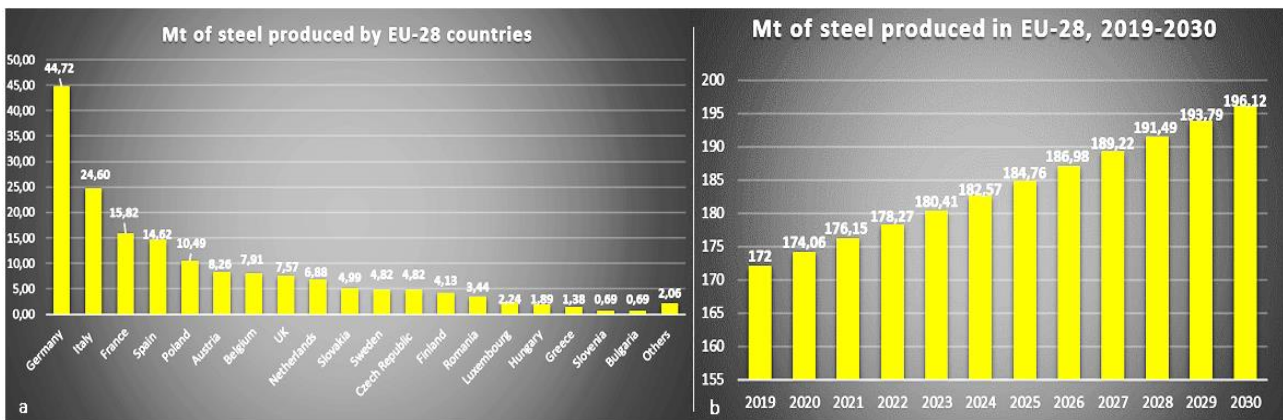

Figure 26. a) EU-28 steel production by country (Million tonnes), 2019; b) EU-28 steel production forecast (2019-2030)

Production data: The EU-28 region has roughly a market share of 10% in both production and demand, ranking second among the various regions in the global steel market (behind Asia region, which has a market share of about 69% in which China only has roughly the 49%).

The European steel production will reach roughly 172 Mt of crude steel at the end of 2019 and is mainly concentrated in Germany, Italy, France, Spain and Poland that together produce almost the 65% of the total

³³ Data from the project proposal.

³⁴ World Steel Association, EIU forecast.

³⁵ "worldsteel Short Range Outlook April 2019". <https://www.worldsteel.org/media-centre/press-releases/2019/worldsteel-short-range-outlook-april-2019.html>



European steel.³⁶ From 2019 to 2030 is expected a growth of about 1.2% per year and this would amount to a production of around 200 Mt of crude steel in 2030.³⁷

In 2017, the quality of crude steel produced concerned mainly the carbon steel non-alloy with the 78.4% of the steel produced, followed by the carbon steel other alloy (17.2%) and the stainless steel (4.4%).

The crude steel produced is then worked in rolling mills, always inside the steel mills, for producing finished steel. In the table below is shown the EU total finished steel production by product, from 2015 to 2017:

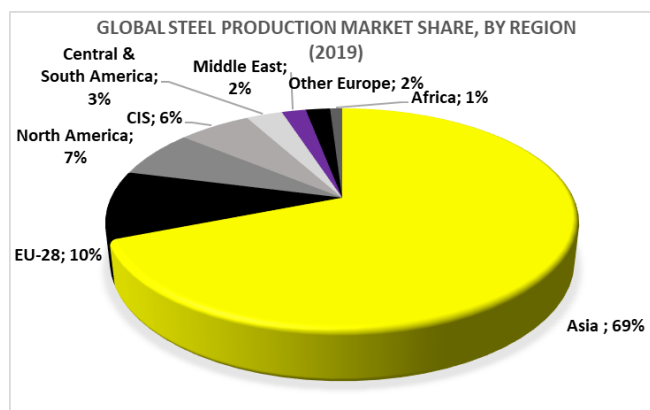

Figure 27. Global steel production by region, 2019

Table 9: EU total finished steel production by product (Source: Eurofer)

	2015	2016	2017
Total hot rolled (Million tonnes)	150.991	150.404	153.857
➤ of which flat products:	92.437	92.200	94.809
Quarto Plate	10.936	10.573	10.953
Hot Rolled Wide Strip	80.024	79.941	82.073
Other flat products	1.477	1.686	1.783
➤ of which long products:	58.554	58.204	59.048
Wire Rod	20.825	20.451	21.221
Rebars	12.763	13.191	12.487
Merchant Bars	12.774	12.319	12.930
Heavy Sections	8.894	9.401	9.605
Other long products	3.298	2.842	2.805
Products obtained from upstream production - from Hot Rolled Wide Strip			
➤ Cold Rolled Flat	44.780	45.164	45.927
➤ Hot Dipped Metal Coated	27.299	27.362	28.060
➤ Organic Coated	4.574	4.863	4.941

Demand data: After showing the EU steel production, the demand analysis needs to consider the apparent steel use/consumption (ASU: the supply of all steel products delivered to the EU-28 market by domestic producers in the EU and by third country exporters), which differs from the real consumption as it recognises changes in stock levels (the difference between the real steel consumption and the changes in stock levels in steel-using sectors determines the steel demand). The following table shows the steel-using sectors share in

³⁶ "European Steel in Figures 2018", Eurofer.

³⁷ Data from the project proposal.

total steel consumption and their related SWIP index:³⁸ *Steel-Weighted Industrial Production (SWIP) index is used to calculate the changes in stock levels and allows to estimate changes in outputs production and the related economic activities in the industrial sectors requiring steel.*

Table 10: EU Steel consumption per Steel-using sectors and EU Steel Weighted Industrial Production (SWIP) index (Source: Eurofer)

	Share in total steel consumption (2018)	SWIP 2018	SWIP 2019	SWIP 2020
Construction	35%	4.8%	2.1%	1.7%
Mechanical engineering	14%	3.7%	0.4%	0.8%
Automotive	18%	0.6%	-0.2%	1.6%
Domestic appliances	2%	-0.8%	-0.1%	2.2%
Other Transport	2%	8.2%	2.3%	1.4%
Tubes	13%	-1.9%	-0.2%	1.0%
Metal goods	14%	1.8%	-0.4%	0.8%
Miscellaneous	2%	2.2%	1.0%	2.4%
Total	100%	2.8%	0.9%	1.1%

The table above shows that the output in the EU's steel-using sectors is forecast to grow by 0.9% in 2019 and by 1.1% in 2020. The weakened prospects for production growth in EU steel-using sectors over the 2019-2020 period will inevitably translate into only very moderate growth of real steel consumption over that period.

Import and Export:

According to Eurofer's data, the outlook for EU steel demand is subdued. The base case scenario for the development of final steel use shows only marginal growth in 2019 and 2020. In fact, EU steel consumption is forecasted to grow almost unnoticed by 0.2% in 2019 and by 0.5% in 2020, reaching 163 million tonnes in 2019 and 164 million tonnes in 2020. Further, there is a trend for increasing third-countries import. Given the uncertainty that currently surrounds the EU steel market in terms of demand and supply fundamentals, steel inventories will be managed with care.

In the final quarter of 2018 domestic deliveries from EU mills to the EU market decreased by 2.1% compared with the same period of 2017. This was the result of third country imports growing by 16.3% year-on-year within a context of flattening steel demand growth over that timeframe. *Imports amounted to 9.6 million tonnes and accounted for 24.7% of EU steel demand. Over the whole year 2018 third country imports rose by 12.6% which contrasts sharply with the 1.7% rise in domestic deliveries.* The preliminary safeguard measures imposed by the EU Commission in July 2018 were supportive to limiting import volumes in the second half of the year compared with the extraordinary high import volumes that landed in the EU in the first half (this aspect will be deepened in the paragraph 5.3.5.2).

³⁸ "ECONOMIC AND STEEL MARKET OUTLOOK 2019-2020", 7 May 2019, Eurofer.



Market Supply of finished products: After having analysed the outlook for EU steel demand up to 2020, it is possible to highlight the market supply from 2015 to 2017 for the finished steel products, as per the table below:

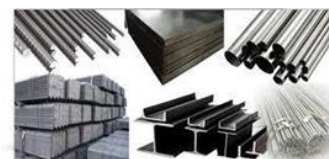

Table 11: Market supply of finished steel products (source: Eurofer)

		2015	2016	2017	% shares (2017)
Total Flat products (Million tonnes)					
Non-alloy and other alloy steels	Eu deliveries	73.744	74.590	74,729	80.8%
	Imports, third countries	15.818	17.797	17,764	19.2%
Stainless steels	Eu deliveries	3.748	4.052	3.944	73.2%
	Imports, third countries	1.096	1.227	1.447	26.8%
Total Long products (Million tonnes)					
Non-alloy and other alloy steels	Eu deliveries	45.886	47.014	49.111	90.1%
	Imports, third countries	4.993	5.525	5.389	9.9%
Stainless steels	Eu deliveries	1.019	1.076	1.087	77.3%
	Imports, third countries	0.283	0.292	0.319	22.7%

Scrap Market: In addition to the market supply of finished steel products, the STEEL industry is also based on the scrap market (secondary production). In fact, steel has the main feature that makes it reusable without losing its characteristics and it's 100% recyclable. For these reasons, steel is the most recycled material in the world, with over 650 Mt recycled annually, including pre- and post-consumer scrap.



By region, the scrap is produced mostly in mature economies. Indeed, the scrap used with respect to the total feed used in the steelmaking process is the 72% in the US, for example, 54% in the EU, 32% in Japan and 39% in Korea. On the other hand, growing economies produce, and thus use, less scrap steel; 11% of steel in China and 25% of steel in Russia is made through steel scrap. However, China is growing and expecting to use substantially more domestic scrap in the coming years. Turkey uses scrap imports from the EU to help it stand out as a major steel producer from scrap, with 78% of its steel production coming from this route.³⁹

By sector, about 83% of post-consumer steel is recovered for recycling. Global steel recovery rates are estimated at 85% for construction, 85% for automotive (reaching close to 100% in the US), 90% for machinery, and 50% for electrical and domestic appliances.⁴⁰

The EU steel scrap market has reached significant levels in the last years, mainly in terms of consumption and exports from the EU, as it is shown in the table below:

Table 12: EU Consumption, Imports and Exports of Scrap Steel, 2013-2017 (source: Eurofer)

Million tonnes	2013	2014	2015	2016	2017	Average growth rate
Scrap Consumption	91.006	91.563	90.614	88.466	94.009	+0.875%
Scrap Imports	3.191	3.143	2.850	2.740	3.140	-0.025%
Scrap Exports	16.802	16.953	13.763	17.769	20.056	+6.025%

It must be noted, that the scrap consumption considered in the table above comprehends the total amount of steel recycled (end-of-life) and re-used in steelmaking routes. The several types of steel scraps are listed

³⁹ Hydrogen steelmaking for a low-carbon economy- A joint LU-SEI working paper for the HYBRIT project – Stockholm Environment Institute & Lund University, 2018

⁴⁰ <https://www.steeloncall.com/blog/sustainability-of-the-supply-chain/>

in the following table, in which are also specified the level of impurities for each one.⁴¹

Table 13: EU steel scrap specifications

Category	Grade	Cu %	Sn %	Cr, Ni, Mo %
Old scrap	E3	≤ 0.250	≤ 0.010	Σ ≤ 0.250
	E1	≤ 0.400	≤ 0.020	Σ ≤ 0.300
New scrap, low residuals, uncoated	E2	Σ ≤ 0.300		
	E8	Σ ≤ 0.300		
	E6	Σ ≤ 0.300		
Shredded	E40	Σ ≤ 0.250	Σ ≤ 0.020	
Steel turnings	E5M	≤ 0.400	Σ ≤ 0.030	Σ ≤ 1.0
High residual scrap	EHRB	≤ 0.450	Σ ≤ 0.030	Σ ≤ 0.350
	EHRM	≤ 0.400	Σ ≤ 0.030	Σ ≤ 1.0
Fragmented scrap from incineration	E46	≤ 0.500	≤ 0.070	
Ore-based metallics	Pig iron, Direct Reduced Iron, Hot Briquetted Iron	0.002	trace	Σ ≤ 0.15

5.3.2 STEEL Industry Key Players

The steel industry, as seen in the previous paragraph, is globally dominated by Asian market, specifically by China. This also reflects on the countries of origin of most of the main companies in the sector. However, the company that annually produces the largest amount of steel is the European ArcelorMittal, that in 2017 produced 97.03 Mt.

In the following tables, all European companies that produced more than 3.00 Mt in 2017 are reported.

Table 14: EU-28 steel industry key players

EU-28 Companies	Country	Tonnage 2017	Steel Recycling
ArcelorMittal	Luxembourg	97,03 Mt	Yes
Tata Steel Group	India (European also)	25,11 Mt	Yes
thyssenkrupp	Germany	13,22 Mt	Yes
voestalpine Group	Austria	8,15 Mt	Yes
SSAB	Sweden	8,00 Mt	Yes
Salzgitter AG Stahl und Technologie	Germany	7,31 Mt	Yes
CELSA Steel Group	Spain	7,02 Mt	Yes
Hüttenwerke Krupp Mannesmann	Germany	5,90 Mt	Yes
RIVA Group	Italy	5,87 Mt	Yes
Outokumpu Oyj	Sweden	3,28 Mt	Yes
Acciaieria Arvedi Spa	Italy	3,19 Mt	Yes

Table 15: Other Europe steel industry key players

Other Europe Companies	Country	Tonnage 2017	Steel Recycling
EVRAZ Group	Russia	14.03 Mt	Yes (Evraz Canada)
Magnitogorsk	Russia	12.86 Mt	Yes
Severstal	Russia	11.65 Mt	Yes
Metinvest	Ukraine	9.59 Mt	Yes
ERDEMIR Group	Turkey	9.20 Mt	Yes
Mettalinvest	Russia	4.76 Mt	Yes
ICDAS	Turkey	4.31 Mt	Yes
Mechel	Russia	4.27 Mt	Yes
Habas	Turkey	3.51 Mt	Yes
ISD Corporation	Ukraine	3.41 Mt	Yes
TMK	Russia	3.24 Mt	Yes

⁴¹ https://www.metallics.org/assets/files/Public-Area/Fact-Sheets/_5_Basic_Pig_Iron_in_EAF_Fact_Sheet_rev3.pdf



5.3.3 STEEL Industry Sector Description:

5.3.3.1 Employment & global turnover

The STEEL Industry contributes significantly to the European economics. In fact, as seen previously, there are lots of steel-using sectors, therefore we must not only count the direct contribution given by the sector but also the indirect one (including all the Steel Supply Chain) and the induced one (including all spending of Steel income). Counting direct, indirect and induced employment, there are as many as 2.5 million people that worked in and around the industry in 2017, with 320,000 direct job in the industry producing on average 170 million tonnes of steel per year. The multiplier effect (the ratio of total activity to direct activity) of the 320,000 direct jobs in the sector is 7.7 times, an outsize impact.

The European steel industry has a turnover of around €170 billion (only deriving from the total sector sales), eight times the industry’s direct Gross Value Added, larger than comparable manufacturing industries. Counting direct, indirect and induced factors, the GVA of the European steel industry was upwards of €128 billion in 2017. More specifically, European steel industry GVA per worker is around 11% above the average for the overall EU economy, and some 7% higher than that of the wider EU manufacturing sector.⁴²

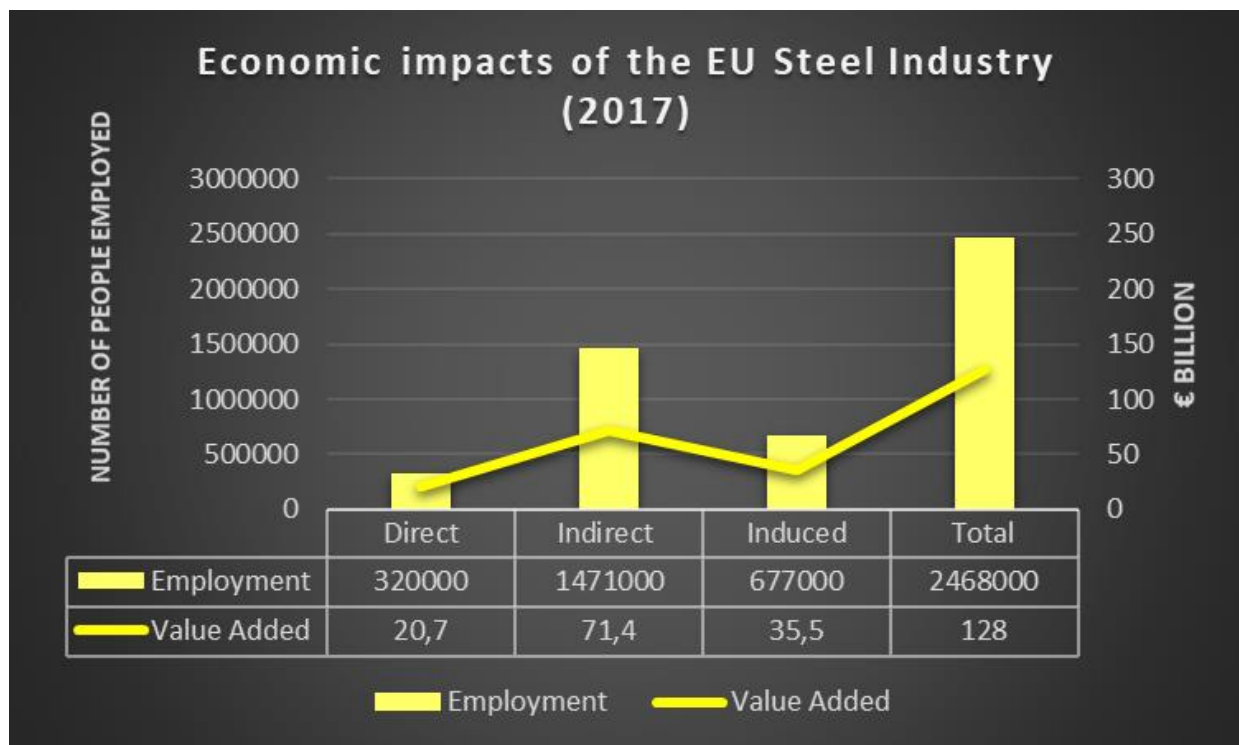

Figure 28. Economic impacts of the EU Steel Industry, 2017 (source: Eurofer)

⁴² Data from various Eurofer reports.

5.3.3.2 Process Routes

Steel can be produced using different raw materials and methods. It is possible to distinguish three alternative steel production routes, as it is shown in Figure 29

- If a Blast Furnace (BF) with a Basic-Oxygen Furnace (BOF) are used for steelmaking it is called an **integrated route**;
- The second way for steelmaking is via Direct Reduction (DR) and Electric-Arc Furnace (EAF).
- The third route is based on the **direct use of recycled steel (scrap)**. (The technologies are detailed in the paragraph 5.3.3.4).

Following this division, it is possible to analyse step by step the supply chain of the three different routes identified:

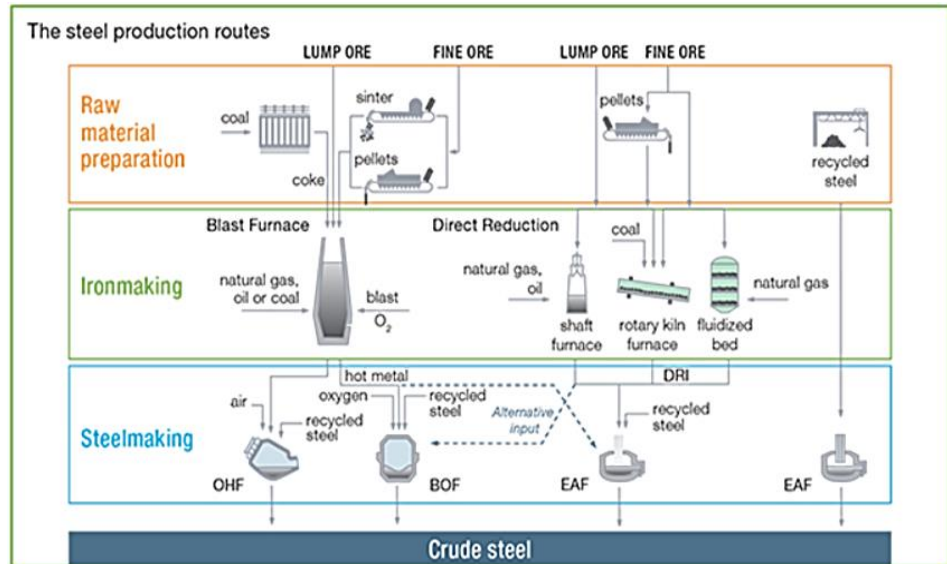

Figure 29. Steel Supply Chain (source: World Steel Association)

1. **BF-BOF (/BF-OHF) route:** The steelmaking starts with the supplying from mining companies of the raw materials that are mainly iron ore (lump ore or fine ore), coal for coking, and mineral aggregates. When the raw materials arrive in the steel mills, it starts an integrated process that consists in: i) *Raw material preparation*, with sintering or pelletizing raw materials; ii) *Ironmaking*, the production of hot metal with the prepared raw materials via Blast Furnace; iii) *Steelmaking*, the production of crude steel with the hot metal and recycled steel via BOF (or OHF). The BF-BOF route is the most used way for steel production and represents about 70% of the world steel production. A variation of this process is the use of a smelting reduction (SR-BOF) route, which is based on the combustion of coal for the reduction of iron ores with or without agglomeration, but which currently covers only 0.4% of world production of the steel⁴³ and for this reason it won't be deepened.
2. **DR-EAF route:** The steelmaking starts with the supplying of the raw materials that are mainly iron ore from mining companies and a reducing agent (natural gas or coal). When the raw materials arrive in the steel mills, it starts a process that consists in: i) *Raw material preparation*, with iron ore pelletizing; ii) *Ironmaking*, the production of Direct Reduced Iron (DRI) thanks to a Direct Reduction obtained via shaft furnace, rotary kiln furnace or fluidized bed; iii) *Steelmaking*, the production of crude steel with the recycled steel and DRI via EAF. This route produces about the 5% of the world steel.
3. **EAF route:** The steelmaking starts from the recycled steel supplying and ends with the production of crude steel via EAF using only the recycled steel. This is possible because the Electric-Arc Furnace

⁴³ "Ironmaking and Steelmaking Processes: Greenhouse Emissions, Control, and Reduction", P. Cavaliere, 2016.

allows the steelmaking with 100% recycled steel as inputs (more details in paragraph 5.3.3.4). The scrap-EAF route accounts about the 25% of the global steel production.

It can be noted that the figure above considers also hot metals as alternative input for EAF: in this case the liquid metal is cast into ingots before being charged to the steel plant and is named “Pig iron” (it can be produced also smelting ilmenite in electric furnaces, but this is a rare case). Many EAF operators prefer to use Pig Iron to blend with scrap and other feedstock materials due to its high ferrous content, low gangue, and chemical purity (on average, Pig Iron makes up between 5-10% of the global EAF metallics charge but in some parts of the world where scrap is scarce, Pig Iron can be used at up to 60% of the charge).⁴¹ Due to these favourable features, the Pig iron in recent years is more and more used in EAFs as one of raw materials.⁴⁴

Eventually, the produced crude steel passes through rolling mills, which transform it into one of the finished steel products as analysed in the table “Market supply of finished steel products (source: Eurofer).

5.3.3.3 Cross-sectoral Value-chain

The Steel Supply Chain, as just described, can comprehend mining companies and sometimes scrap metal buyers for raw materials supplying, and Steel mills for steelmaking. On the other hand, as already specified before, the steel industry uses recycled steel as secondary raw material. Thus, a circular value-chain can be defined, as shown in the figure below.

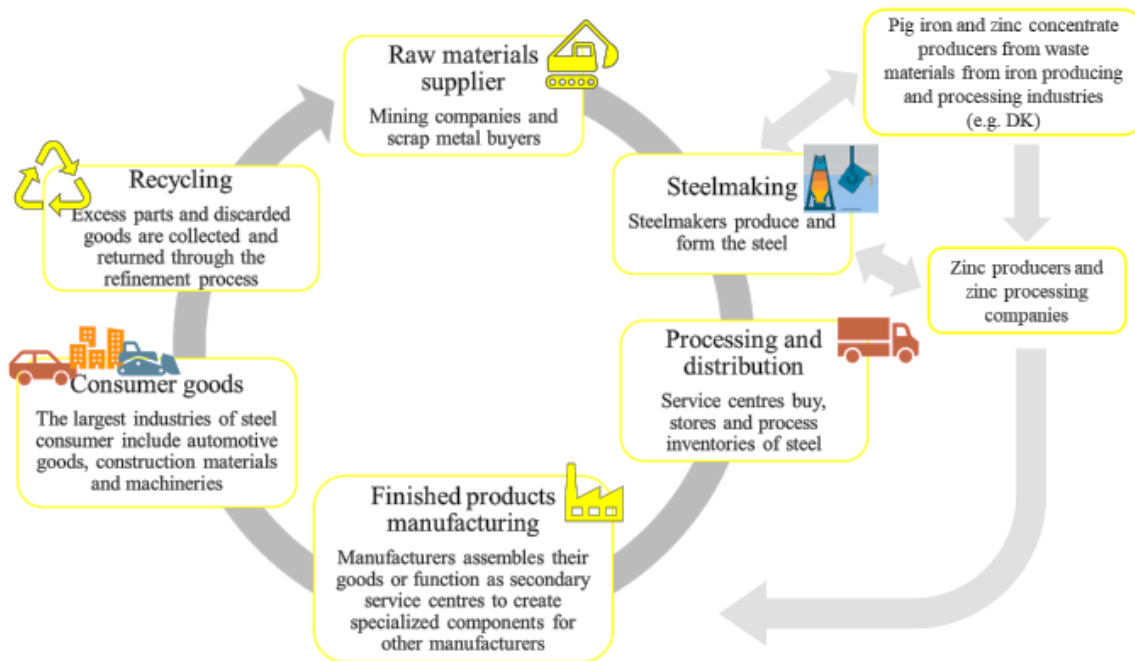

Figure 30. Common steel value chain integrated with DK business

The represented steel value chain highlights an intermediate products market. In fact, on the right, it spots the supply of steel intermediate products, e.g. pig iron and zinc, from the recycling of steel dusts. They can be produced with the aim of reselling it to other steelmakers for the steel production in the EAFs for example,

⁴⁴ The project partner DK has developed a technology to produce Pig iron also from waste materials from iron producing and processing industries.



following the life cycle pattern shown in the figure, where, eventually, steel scraps are purchased by companies that re-use it directly for producing new steel or by companies that re-sell it to steelmakers.

The steel value chain is strongly characterized by the bullwhip effect, that is a phenomenon whereby a small change in demand among end customers is amplified as it progresses upstream along the supply chain. This has the potential to cause cycles of excess inventory and large amounts of stocks, severe backlogs, inadequate product forecasts, unbalanced capacities, poor customer service, uncertain production plans, high backlog costs, and lost sales.⁴⁵ The DESTINY project can contribute to minimize this effect, adapting the steel production to the market demand thanks to the switch and go and the on-demand production.⁴⁶

Thus, the described steel value chain has some weaknesses and some strengths that are illustrated in the following table:

Table 16: Steel value chain assessments

VALUE CHAIN STEPS	EFFICIENCY	ACCEPTABILITY	SUSTAINABILITY
Raw material supply	Low – Depending on logistics and availability	Low – More stringent policies on low sustainable raw materials	Low – Ores extraction from earth's soil
	High – If scrap is used	High – Steel scraps	High – Steel scraps
Steelmaking	Low – High cost and risk of bullwhip effect	Low – More stringent policies on low sustainable processes	Higher if scraps are used Affected by fuel consumption high-energy processes
Pig iron and zinc concentrate production from waste dust	Low – It isn't integrated in the steelmaking process; it needs transport and causes additional costs	High – Policies favour production from waste	Low – Emissions and high demand of fossil energy
Zinc production and processing	Low – Often it isn't integrated in steelmaking process, but it causes additional costs	High – Necessary to make the steel products corrosion resistant	Low – High energy consumption and related emissions
Steel processing and distribution	Low – Depend on logistics (deliver customized steel sheets to manufacturers)	High – Eases the transition from steelmakers to end users	Low – Long distance deliveries and related consumptions
Finished products manufacturing	It depends on consumer goods demand and steel sheets prices	Higher if processes are more sustainable	Low - High energy consumption processes related emissions
Consumer goods (construction, automotive, machinery industries)	It depends on previous steps	More and more demand from society and	Low – High energy consumption processes related emissions
Recycling	High – Depending on costs	High – Push towards Circular economy	High – Does not require upstream processes and therefore avoids the related impacts
All value chain	Low – Risk of bullwhip effect (many steps between steel production and end consumers)	High – Circular economy; High GVA and Employment	Low – High energy consumption and CO ₂ -related emissions

⁴⁵ "Steel Supply Chains Management by Simulation Modelling", M. Sandhu, P. Helo, Y. Kristianto, 2013.

⁴⁶ Data from the project proposal.



5.3.3.4 Used Technologies

As it is shown in the paragraph 5.3.3.2 5.3.3.1, the technologies used for steelmaking are mainly three: Basic Oxygen Furnace (BOF), Open-Hearth Furnace (OHF) and Electric-Arc Furnace (EAF).

The BOF and OHF technologies have both an integrated route with the Blast Furnace that is used for ironmaking, while the EAF technology can have a non-integrated route thanks to its steelmaking feature that allows to produce steel also directly with steel scrap (see figure aside⁴⁷). Below, the technical features of the three different steelmaking technologies are described:

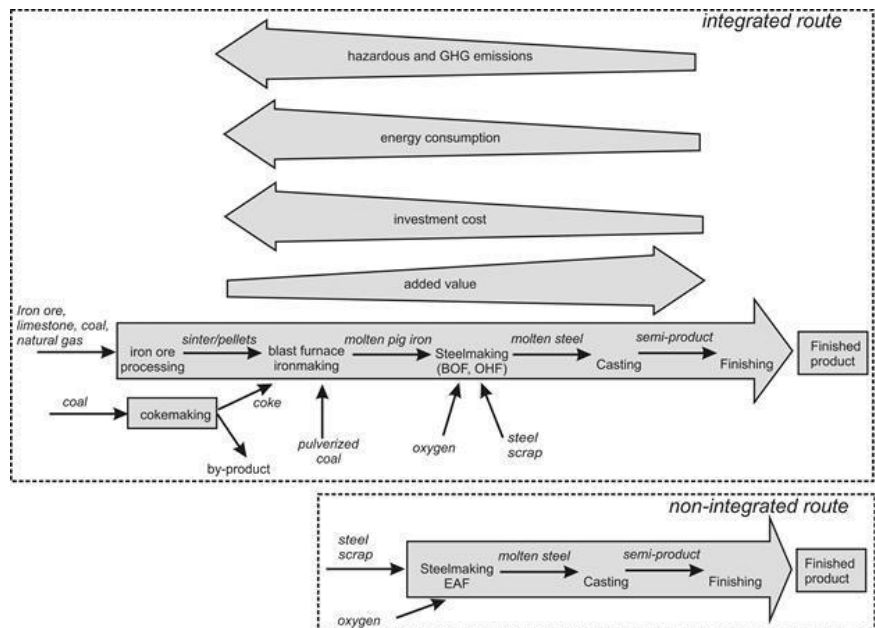

Figure 31. Technologies used for steelmaking

1. **Open-Hearth Furnace:** It has been almost completely replaced by BOF and EAF steelmaking in many highly industrialized countries.⁴⁸ The open-hearth furnace (OHF) uses the heat of combustion of gaseous or liquid fuels to convert a charge of scrap and liquid blast-furnace iron to liquid steel. The high flame temperature required for melting is obtained by preheating the combustion air and, sometimes, the fuel gas. OHFs vary considerably in size, having been built for heats of 10 to 600 tonnes; the hearth of a 150-tonnes-capacity OHF is approximately 15 metres long and 5 metres wide. Bulk materials, such as scrap, cold blast-furnace iron, ore, limestone, coke, and alloying agents, are charged through the furnace doors in small boxes of one- to two-cubic-metre capacity. The boxes are brought to the OHF on small railroad buggies, and a charging machine then moves one box after another through a door, turns them over, and dumps their contents onto the hearth.
2. **Basic-Oxygen Furnace:** Basic Oxygen Furnace (BOF), also named Basic Oxygen Furnace Steelmaking (BOS) or Linz-Donawitz-Verfahren steelmaking or the oxygen converter process, is a method in which both molten pig iron and steel scrap are converted into steel with the oxidizing action of oxygen blown into the melt under a basic slag. BOFs include conventional top-blown furnaces, bottom blown furnaces, and various mixed blowing configurations and inert gas bottom stirring modifications. The top blown basic oxygen furnace is equipped with the water-cooled oxygen for blowing oxygen into the melt through 4-6 nozzles; the bottom blown basic oxygen furnace is equipped with 15-20 tuyeres for injection of oxygen or lime powder containing oxygen.⁴⁹ To produce 1,000 kg of crude steel, the main inputs for the BF-BOF route are roughly: 1,370 kg of iron ore (accounts over just 50% of BOF steel costs); 780 kg of coal; 270 kg of limestone; 125 kg of steel scrap; self-sufficient in energy. A BOF can be charged with as much as 30% scrap.⁵⁰

⁴⁷ "Comparative Study of Iron and Steel Industry Transition in the Countries of Central-East Europe and Former Soviet Union", V. Shatokha, 2017.

⁴⁸ <https://www.britannica.com/technology/steel/Open-hearth-steelmaking>

⁴⁹ <https://www.steel-technology.com/articles/oxygenfurnace>

⁵⁰ <https://www.worldsteel.org>

3. **Electric-Arc Furnace:** The electric-arc method uses high-current electric arcs to melt DRI and steel scrap (or steel scrap alone) and convert them into liquid steel of a specified chemical composition and temperature. The major charge material of electric-arc steelmaking is scrap steel, and its availability at low cost and proper quality is essential. The electric-arc furnace (EAF) is a squat, cylindrical vessel made of heavy steel plates; it has a dish-shaped refractory hearth and three vertical electrodes that reach down through a dome-shaped, removable roof.⁵¹ To produce 1,000 kg of crude steel, the main inputs for the DRI-EAF route are: 710 kg of steel scrap (account around 75% of EAF steel cost); 586 kg of iron ore; 150 kg of coal; 88 kg of limestone; 2.3 GJ of electricity. An EAF can be charged with 100% steel scrap.⁵² Recycling this steel accounts for significant energy and raw material savings: over 1,400 kg of iron ore, 740 kg of coal, and 120 kg of limestone are saved for every 1,000 kg of steel scrap made into new steel.⁵³

To date, steel is mainly produced via BF-BOF and scrap-EAF routes. A big difference between the two steelmaking processes, besides the inputs needs and savings previously analysed, is the capital investment costs involved: whilst a typical integrated (i.e. BOF-route) steel mill today costs ~€980 per tonne of installed capacity, a medium-size EAF-route mini-mill today costs under €270 per tonne in terms of the initial capital outlay.⁵⁴ Beside these just listed, there are also relevant differences on the energy required that is summarized in the following table.⁵⁵

Table 17: Energy required of key processes in Iron and Steel industry.

Process	Electric energy (kWh/t)		Thermal energy (kWh/t)	
	min	max	min	max
BF-BOF route (sum of the processes below)	73	405	3,517	9,117
- Coke production	6	64	906	1,306
- Sintering pelletising	25	44	358	561
- Blast Furnace	31	236	2,236	6,783
- BOF	11	61	17	467
EAF route	403	747	22	517

As the table shows, for BF-BOF route the highest consumption is of thermal type, related to the furnaces and the peak of thermal consumption is in BFs. On the opposite, EAF reduces widely the thermal energy consumption and does not increase proportionally the electric energy consumption, thus making it less energy-intensive and preferable, when possible, due to availability of scraps and the quality of the final product.

The main differences of the two technologies that have just been analysed are summarized in the table below:

⁵¹ <https://www.britannica.com/technology/steel/Electric-arc-steelmaking>

⁵² <https://www.worldsteel.org>

⁵³ <https://www.steeloncall.com/blog/sustainability-of-the-supply-chain/>

⁵⁴ <https://www.steel-technology.com/articles/oxygenfurnace>

⁵⁵ Data from the deliverable 4.2 of EU-Merci project. <http://www.eumerci.eu/wp-content/uploads/2018/01/Iron-and-Steel.pdf>



Table 18: Main differences between BF-BOF and DR-EAF routes.

	BF-BOF	DR-EAF
Raw materials required to produce 1 t of crude steel	1,370 kg of iron ore* 780 kg of coal 270 kg of limestone 125 kg of steel scrap	710 kg of steel scrap** 586 kg of iron ore 150 kg of coal 88 kg of limestone
Possibility of charging with 100% steel scrap	No	Yes (In this case over 1,400 kg of iron ore, 740 kg of coal, and 120 kg of limestone are saved to produce 1 t of crude steel)
Range of Electric energy required (kWh/t)	73-405	403-747
Range of Thermal energy required (kWh/t)	3,517-9,117	22-517
Investment required per tonne of installed capacity	~ €980	~ €270

*It accounts over just 50% of BOF steel costs; ** It accounts around 75% of EAF steel costs.

The EU steelmaking processes are also mainly based on BOF and EAF routes. In the table below the shares of both technologies per EU crude steel outputs are shown, from 2015 to 2017:

Table 19: EU crude steel output by production route, 2015-2017 (source: Eurofer)

Million tonnes	2015	2016	2017	% shares 2017
Basic-Oxygen Furnace	100.624	97.664	100.165	59.2%
Electric-Arc Furnace	65.418	64.378	68.871	40.8%
Total crude steel	166.042	161.982	168.992	100%

Considering a higher production capacity of BOFs with respect to EAFs and that after steelmaking the steel is processed in other sites, the next Figure 32 shows a map of these sites.

After having analysed the steelmaking technologies market, for DESTINY it is particularly necessary to refer to the technologies used in the **DR-EAF route (to date, accounting for about the 5% of the steel globally produced⁵⁶)** to produce intermediate products such as DRI. Direct Reduced Iron is the product of the direct reduction of iron ore in the solid state by carbon monoxide and hydrogen derived from natural gas or coal. There are several processes for direct reduction of iron ore that can be divided in two categories:⁵⁷

⁵⁶ "Ironmaking and Steelmaking Processes: Greenhouse Emissions, Control, and Reduction", P. Cavaliere, 2016.

⁵⁷ <https://www.metallics.org/dri-production.html>



- Gas-based processes, in which shaft furnaces and fluidizing beds are considered, accounting for 82% of 2016 DRI production;
- Coal-based processes, in which rotary kiln and hearth furnaces are considered, accounting the remaining 18%.

Indeed, with the high prices of steel scrap in the international market, coupled with the difficulty in the importing process for small-scale units, DRI has become the most viable alternative to steel scrap. In view of shortage of steel scrap and high prices of scrap, the secondary steel producers can depend on DRI as the metallic feed material to produce steel. Using DRI in EAF increases furnace productivity and reduces both electrode and power consumption.

For all the mentioned furnaces, there are several processes that can be summarized as done in the following figure, in which they are divided by furnaces type, gas or coal process and required iron ore form.

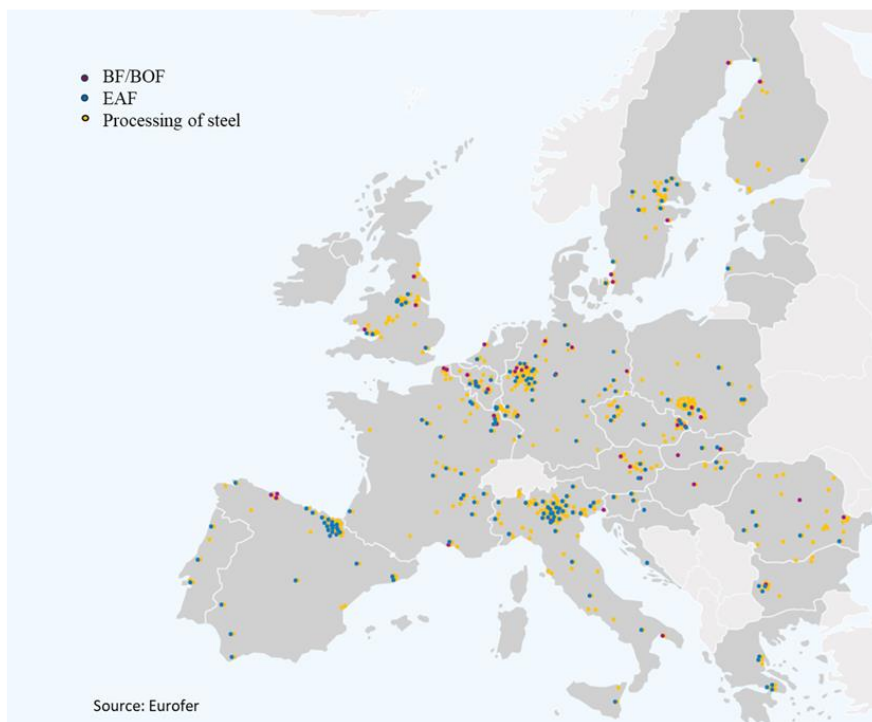

Figure 32. Steel industry production sites in EU, 2017 (source: Eurofer)

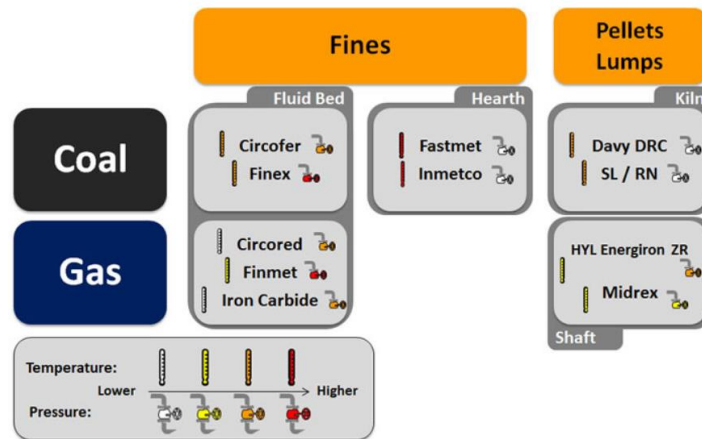

Figure 33. Direct reduction processes for iron (source: International Iron Metallics Association)

Case Studies: among these, Midrex® is the main one used in shaft furnaces, Finmet in fluidizing beds and SL/RN in rotary kiln furnaces. **Midrex® alone accounts roughly the 60% of total DRI production.** Below are analysed the features of each one, that reflect the characteristics of the three considered technologies:⁵⁸

- **SL/RN process (rotary kiln):** Normally, the rotary kiln is 60–125 metres long and 4–6 metres in diameter and is capable to produce from 160,000 t/y to 200,000 t/y.⁵⁹ About 45% of coal is charged with iron ore from the feed end and the remaining 55% from the discharge end of the kiln. Depending on the properties of ore and coal, the temperature in the isothermal zone is maintained between 1000 and 1050 °C. After retention time of 8–10 hours in the kiln, the DRI is discharged via a transfer chute into a cooler. Energy consumption decreases because no coke oven and sinter plants are required: the total electricity consumption is 999,74 kWh/t liquid steel.⁶⁰
- **Midrex® process (shaft furnace):** The plant includes two shaft reduction furnaces that vary from 3,4 to 7 metres inside diameter and has a total capacity of more than 2.5 Million tonnes per year.⁶¹ The average energy consumption of this plant is approximately 9.62 GJ/t (2,672 kWh/t) of DRI, lower than Blast Furnace.⁶² The charge of the Midrex shaft consists of around 60% pellets and 40% lump ore of a particular type. Reducing gas is produced by continuous catalytic reforming of natural gas with CO₂ and H₂O contents in the recirculated shaft furnace top gas and the reforming reactions take place at a temperature of 950 °C. Iron ore reduction is performed in the vertical, cylindrical shaft furnace by the H₂ and CO components of the reducing gas while the iron ore is continuously charged from the top; the reduction gas enters the shaft furnace at the bottom of the reduction zone with a temperature of 800–900 °C. The residence time for obtaining 93-94% metallized DRI is between 5 and 6 hours. As the metallized material passes down through the conical section of the shaft, it is cooled by inert gas.
- **Finmet process (fluidizing bed):** The Finmet® Process can produce 2.2 Mt/Year.⁶³ The process uses a train of four fluidized bed reactors in which the gas and solids moving in counter-current directions

⁵⁸ "Direct Reduced Iron: Production", 2009, Encyclopedia of Iron, Steel, and Their Alloys.

⁵⁹ <https://www.outotec.com/products/direct-and-smelting-reduction/sl-rn-process/>

⁶⁰ "Encyclopedia of Iron, Steel, and Their Alloys (Online Version)", G. E. Totten, R. Colas, 2016.

⁶¹ https://www.midrex.com/assets/user/media/MIDREX_Process-Brochure.pdf

⁶² <http://ietd.iipnetwork.org/content/midrex%C2%A9-process>

⁶³ http://www.fsap-hk.com/product/FSAP_3b_HBI-Keynote%20Presentation%20Kopie%202.key.pdf

come into contact throughout the entire reactor train. The ore fines are fed continuously to the reactors out of the lower lock hopper, which is always maintained at the reactor pressure of 11–13 bar. In the topmost reactor, the feed is preheated to 550–570 °C by the reducing gas coming from the lower reactor. The composition of the recycled gas entering the last reactor is adjusted in accordance with the desired carbon content of the product. The temperature in the last reactor is maintained at around 780–800 °C. The final product is DRI with 93% metallization. The average energy consumption of this plant is approximately 12.4 GJ/t (3,444 kWh/t) of DRI, lower than Blast Furnace.⁶⁴

After having described the three processes, in the following table their pros-and-cons, which can be outlined in the two categories of coal-based (rotary kilns) and gas-based (shaft furnaces and fluidizing beds).

Table 20: Features of processes for ironmaking in steel industry

	Coal-based processes (SL/RN)	Gas-based processes (Midrex and Finmet)
Disadvantages	<ul style="list-style-type: none"> - Lower economy of scale. - Low carbon content in the product (<1.0%). - Lower productivity (0.1-0.2 Mt/day). - Hot feeding to the steelmaking furnace and hot briquetting are not possible due to the presence of residual char and ash in DRI. 	<ul style="list-style-type: none"> - Confined to the areas where natural gas is available in abundance at a reasonable price. - Higher energy consumption (2.6-3.4 kWh/Kg)
Advantages	<ul style="list-style-type: none"> - Do not require high-grade coal that is scarcely available. - Use non-coking coal. - Can be installed at lower capacity. - Can be easily installed at places where small reserves of coal and iron ore are available. - Modules of small-scale operation are available. - No coke oven and sinter plants required: lower energy consumption. Electricity consumption is 1 kWh/Kg. 	<ul style="list-style-type: none"> - Higher productivity (2.2-2.5 Mt/day). - Higher metallization and carbon content in the product (>1.0%). - Less capital cost per tonne of installed capacity (1.8-2 times lower). - Better plant availability (lower maintenance problems). - Environmental pollution (gas is a clean source of fuel).

DESTINY's microwave technology has the potential to position within the production of intermediate products to feed the final steelmaking technologies via BOFs and EAFs (DRIs). Indeed, DESTINY's microwave aims to produce higher reduced iron ore pellets or sinter from steel dust recycling thanks to an exclusive technology already developed by DK, adding also the production of zinc by-products, putting the two processes together for the first time inside the still mills (the impacts of this innovation will be explicated in the next paragraphs). To date, the zinc extraction from steel dust is already done and the most efficient process to do it is the Waelz Kiln technology which accounts more than 85% of the market,⁶⁵ but in plants outside the steel mills. The Waelz process is described in the figure below:⁶⁶

⁶⁴ <http://ietd.iipnetwork.org/content/finmet>

⁶⁵ "Zinc Recovery from Steelmaking Dust by Hydrometallurgical Methods", Faculty of Non-Ferrous Metals, AGH University of Science and Technology, 18 July 2018.

⁶⁶ http://www.globalsteeldust.com/waelz_kiln_technology



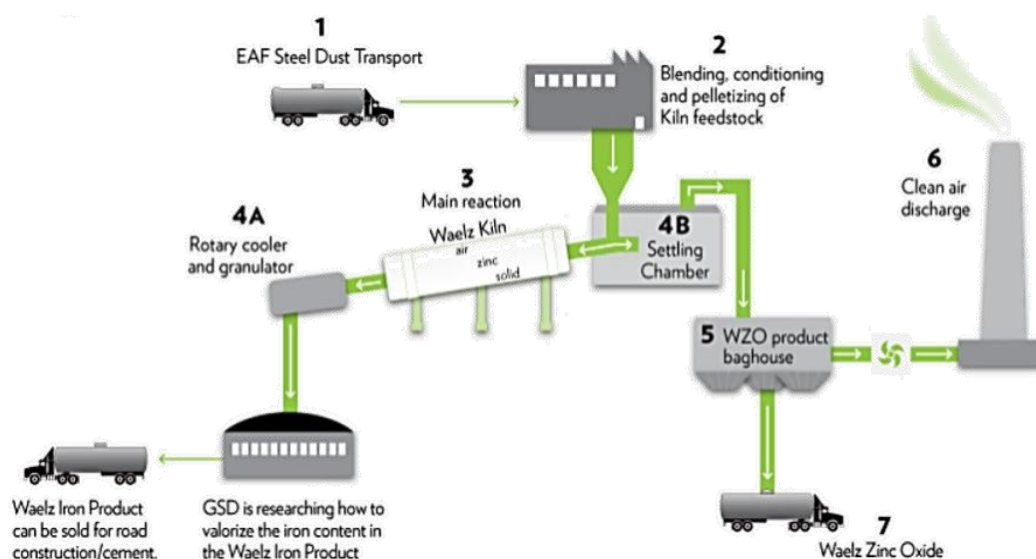

Figure 34. Typical Waelz Kiln Process (source: Global Steel Dust)

The Waelz Zinc Oxide product, at the end of the process, come back in the steel mills or in other finished steel manufacturing industries before its commercialisation.

5.3.4 Zinc Market

Zinc is a 40 Billion USD per year market and is the fourth-most used metal worldwide, behind iron, aluminium, and copper.⁶⁷ The International Lead & Zinc Study Group (ILZSG)⁶⁸ forecasts that the global mined zinc production will rise by 6.2%, reaching 13.48 Mt in 2019 and the global refined zinc production will reach 13.65 Mt in the same year, growing by 3.5%. The global refined zinc demand, instead, is forecast to reach 13.77 Mt at the end of 2019, rising by 0.6% after remaining stable over the past four years.

Production data: when we talk about the production of zinc, we must differentiate the mined zinc from the refined zinc that is then commercialized. Indeed, the zinc is first extracted from mines or other sources and then, to be commercialised, is refined in smelters to produce high grade zinc. In the last few years, the overall production of the zinc was quite volatile, as shown in the table below:

Table 21: Global zinc production, 2015-2019 (source: ILZSG; Zinc Market Overview, Nexa)

Million tonnes		2015	2016	2017	2018	2019	2023
Mined production	zinc	13.62	12.60	12.52	12.76	13.48	15.35
Growth rate		1.53%	-7.49%	-0.63%	1.92%	6.2%	3.3%
Refined production	zinc	13.80	13.56	13.20	13.17	13.65	15.67
Growth rate		3.03%	-1.74%	-2.65%	-0.23%	3.5%	3.5%

⁶⁷ <https://www.zinc.org>

⁶⁸ http://www.mineralinfo.fr/sites/default/files/upload/ilzsg_may_2019_press.pdf

The table shows an increase in production in the current year, also expected for the coming years. As previously mentioned, the mined zinc can be produced either directly from mines, that account about the 90% of the total production, or from secondary sources, mainly EAF steel dusts processing that accounts roughly the 10% of the total production.⁶⁹ The EAF steel dusts processing, indeed, can extract zinc oxide that can be supplied to the zinc smelters to produce high grade zinc.

Europe has different market shares depending on the two different zinc production sources, as shown in the following figures:^{70 71}

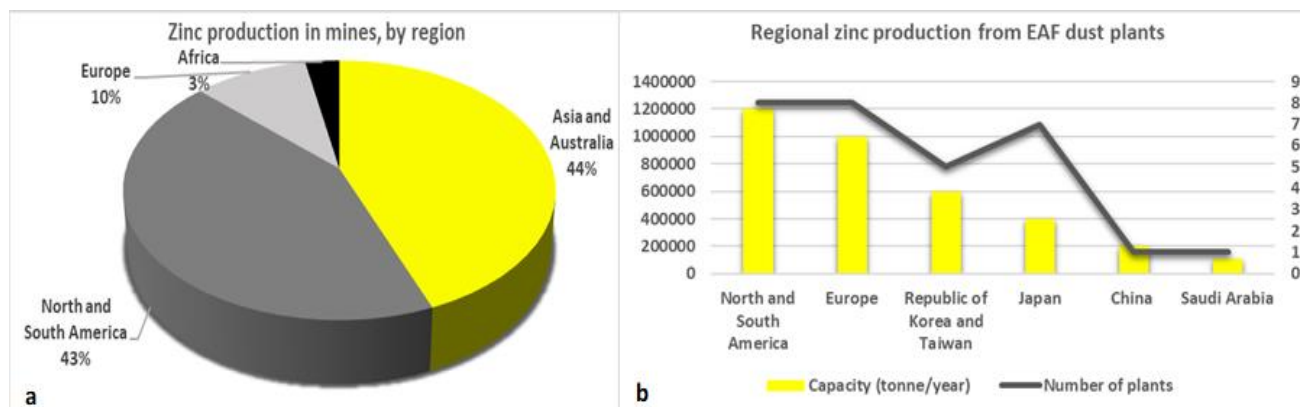

Figure 35: a) Zinc produced in mines, market share by region (source: Greenspec); b) Zinc produced from EAF dusts, by region (source: ILZSG)

Worldwide EAF generates roughly the 2% of steel dusts with a 22% of zinc content, which stands for 1.4 Mtonnes of zinc.⁷²In Europe instead, about 41% of steel is produced by EAF (see the paragraph 5.3.3.4, Table 19) thus, a coarse estimate using the same proportions for zinc content and steel dust, leads to a value of 0.303 Mtonnes/year of zinc from steel dust (the amount is forecast to rise in the following years due to the growth of steel production and the number of EAF plants for steelmaking).

Demand data: the refined zinc consumption was quite steady in the last few years and Europe has the second biggest market share in the global market. The refined zinc demand is forecast to grow at a 2.2% CAGR in the next few years.

⁶⁹ "Zinc Market Overview", Nexa Investor Meeting, October 2018.
⁷⁰ <http://www.greenspec.co.uk/building-design/zinc-production-environmental-impact/>
⁷¹ <http://www.icz.org.br/upfiles/arquivos/apresentacoes/intergalva-2015/5-2-Stewart.pdf>
⁷² "Zinc Market Overview", Nexa Investor Meeting, October 2018.



Table 22: Global refined zinc consumption, 2015-2019 (source: ILZSG; Zinc Market Overview, Nexa)

Million tonnes	2015	2016	2017	2018	2019	2023
Refined zinc consumption	13.63	13.67	13.68	13.68	13.77	15.02
Growth rate	-0.34%	0.29%	0.07%	0%	0.65%	2.2%

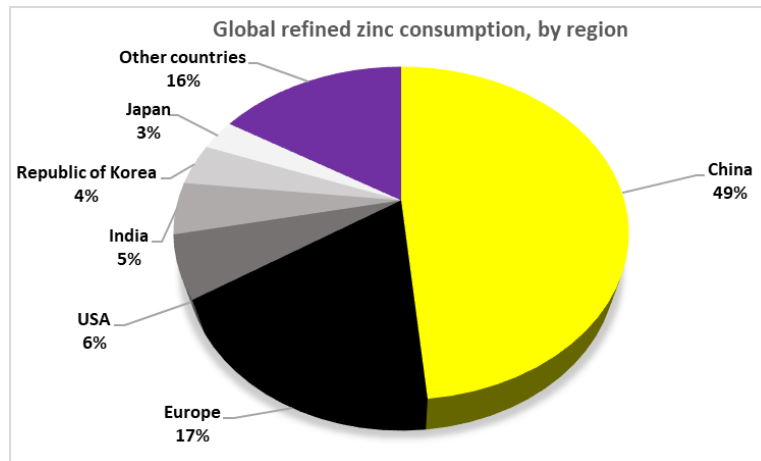

Figure 36: Global refined zinc consumption, by region (source: ILZSG)

Zinc global markets is driven by its application in galvanized steel and iron making and by its final use in the construction and infrastructure sector, as shown in the figures below:

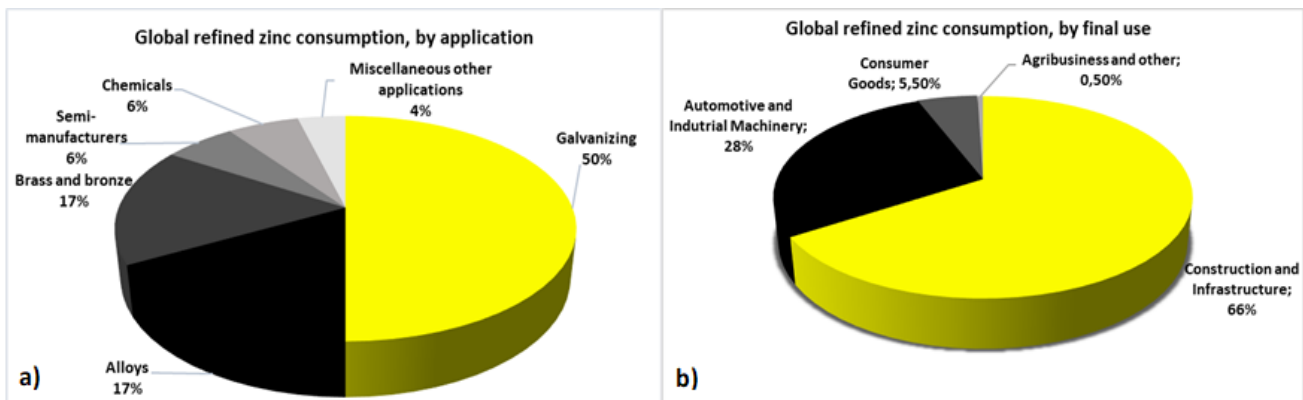

Figure 37: a) Global refined zinc consumption, by application (source: ILZSG); b) Global refined zinc consumption, by final use (source: Zinc Market Overview, Nexa)

Balance: After some years in which the overall refined zinc market has been characterised by a large deficit due to a demand level higher than the global production, in the following years the zinc production is set to grow with a higher rate whilst the demand level will be steadier and the global market balance will turn to surplus.

Table 23: Global refined zinc market balance (source: ILZSG; Zinc Market Overview, Nexa)

Million tonnes	2015	2016	2017	2018	2019	2023
Refined zinc production	13.80	13.56	13.20	13.17	13.65	15.67
Refined zinc consumption	13.63	13.67	13.68	13.68	13.77	15.02
Apparent balance	0.17	-0.11	-0.48	-0.51	-0.12	0.65
% of consumption	+1.25%	-0.8%	-3.5%	-3.73%	-0.87%	+4.33%

Key players: although the market share in zinc production is not very high, among the top ten global companies that produce zinc there are three European companies, which have mines and refineries around the world.⁷³

⁷³ <https://www.thebalance.com/the-10-biggest-zinc-producers-2013-2339743>



Table 24: Major global zinc producers (source: The Balance)

Company	Country	Mines/refineries in the world	Tonnage produced in 2017 (tonnes)	Zinc extraction from EAF dusts
Korea Zinc Group	Korea	Korea	1,100,000	NO
Glencore	Switzerland	In more than 50 countries in Asia, North and South America, Europe, Australia and Africa.	1,090,000	YES (through its subsidiary American Zinc Recycling Corp)
Nyrstar	Switzerland	Belgium, Netherlands Australia, France, USA, Canada, Norway	1,001,000	YES
Hindustan Zinc	India	India	840,000	NO
Nexa Resources	Brazil	Brazil, Peru	570,000	YES
China Minmetals	China	Countries in Asia, Oceania, South America, and Africa.	519,000	N/A
Boliden	Sweden	Sweden, Finland, Ireland, Norway	500,000	YES
Shaanxi Nonferrous Metals	China	China	404,000	N/A
Teck	Canada	Canada, Peru, Chile, USA	295,000	NO
Noranda Income Fund	Canada	Canada	265,000	NO

5.3.5 STEEL Industry Externalities (completing a PESTLE analysis)

5.3.5.1 Environmental and Societal Impacts

The iron and steel industry are one of the biggest industrial emitters of CO₂, accounting for around 2.8 Gt per annum of CO₂ emissions globally, about 8% of global energy system emissions. If the business scenarios remain as usual, the emissions could rise to 3.1 Gt per annum by 2050, with the growth in global steel demand driven by regions that are more unlikely to make significant progress on the decarbonization front. However, the growth of emissions and the balance between different countries will be strongly driven by the changing mix of different production processes: in fact, to date, average BF-BOF furnaces produce emissions of about 2.3 tonnes of CO₂ per tonne of steel produced, DRI with gas as the input produces about 1.1 tonnes, EAF about 0.4 tonnes and less still if the electricity used comes from zero-carbon sources.⁷⁴ Considering these values, and the specific weight of each technology in the steelmaking in the EU-28 (see Table 19Table 19: EU

⁷⁴ "Reaching zero carbon emissions from Steel", Energy Transitions Commission (ETC), 2018. http://energy-transitions.org/sites/default/files/ETC_Consultation_Paper_-_Steel.pdf



crude steel output by production route, 2015-2017 (source: Eurofer) and considering a 5% share of the DR-EAF route also in EU-28), it is possible to deduce that **in 2017 were emitted roughly 263.7 Mt of CO₂ in the EU-28 area, about 1.56 tonnes of CO₂ per tonne of steel produced**. Consequently, if the specific weight of each technology will be the same and if no decarbonization technologies will be applied, in the 2030 roughly 306 Mt of CO₂ will be emitted by EU-28 steelmaking industry. The different levels of CO₂ emission are shown in the figure below. Further, a review of current trends in decarbonization technology is at paragraph 5.3.5.3.

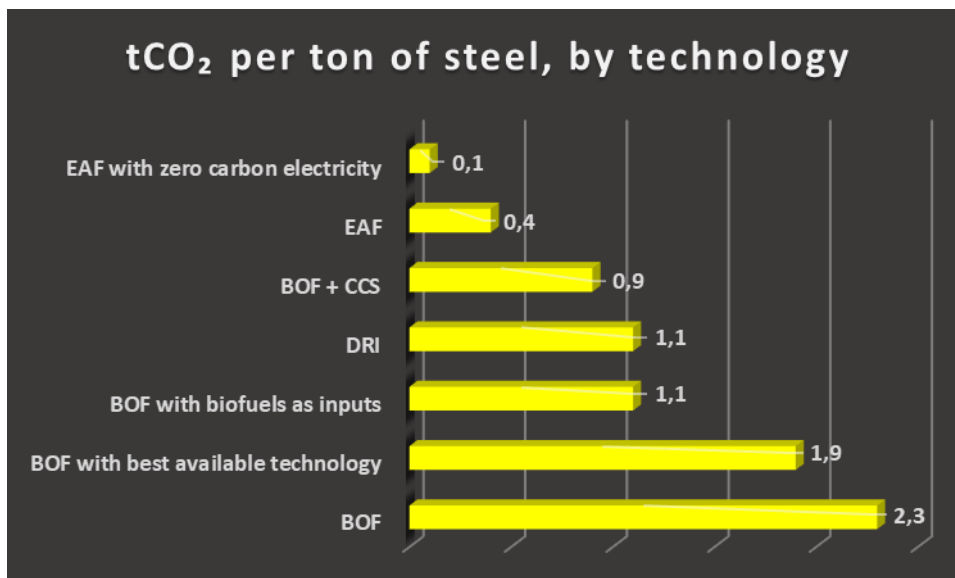

Figure 38. CO₂ emissions by steelmaking technologies

Given these different intensities, the predicted shift in the mix of steel production from BF-BOF to EAF explains why forecasted emissions grow slower than total steel demand growth.

The iron and steel industry, being one of the industries that emit the most CO₂ because it requires an expensive energy consumption, has been attentive for years to the reduction of these emissions and in the last 40 years it has already halved its energy consumption thanks to the greater use of scraps, from a 20% share in the 1970's to around 40% today while the manufacture of iron from iron ore has declined. However, a complete shift to recycling is limited by the availability and quality of scrap, as already said in the previous paragraphs, so the industry needs and is developing new technologies that allow to reduce and/or set to zero the emissions. These technologies, some of which are mentioned in the figure above, will be better described in paragraph 5.3.5.3.

5.3.5.2 Policy, Relevant Standards and Directives

The iron and steel industry emissions are largely regulated. In Europe, there's the Industrial Emissions Directive (IED)⁷⁵ that regulates the standards applicable to airborne emissions as well as discharges to land and water relating to industrial operations. Through this directive, the emission limit values that can be obtained using the BATs have been imposed to become binding values. Within the framework of the IED legislation, BREF documents (BAT Reference Documents) are produced and describe what are considered to be the Best Available Techniques at the different process stages. In the following two tables are summarized

⁷⁵ 2010/75/EU. <https://eur-lex.europa.eu/legal-content/EN/TXT/?uri=CELEX%3A32010L0075>

the limit values relevant for iron and steel production from the existing protocols and the related BAT-associated emission levels.⁷⁶

Table 25: Limit values relevant for iron and steel production from the existing Protocols to the Geneva Convention

Pollutant	Process	Limit values (mg/Nm ³)				
		HM Protocol 1998	Gothenburg Protocol 1999/2005	Gothenburg Protocol 2012	HM Protocol 2012	POP Protocol 2012
SOx	Combustion of coke oven gas		new: 400 existing: 800	400		
	Combustion of blast furnace gas		new: 200 existing: 800	200		
NOx	Combustion of other gaseous fuels		new: 200 existing: 350	new: 200 existing: 350		
	Sinter plant		400	400		
Particulate matter	Sinter plant	50		50		
	Palletisation plant	25 40 g/t pellets		Crushing, grinding and drying: 20 All other process steps: 15		
	Blast furnace	50		Hot stoves: 10		
	Basic oxygen steelmaking			30		
	Electric steelmaking	20		new: 5, existing: 15		
	Hot and cold rolling			20, Bag filter not applicable: 50		
PCDD/F	Sinter plant					0.5 ng/m ³
	EAF plant					0.5 ng/m ³

⁷⁶ "BAT in the Iron and Steel Industry", 2015.

https://www.unece.org/fileadmin/DAM/env/lrtap/capacity_building/BAT_Workshop_2016/7_BAT_in_the_Iron_and_Steel_Industry.pdf



Table 26: BAT-associated emission levels from the UNECE Guidance Documents to the Gothenburg and the HM Protocol

Emissions source		Control measure	BAT-associated emission level (mg/Nm ³)				
			Dust		Hg	SO ₂	NO _x
			GP	HMP			
Sinter plant	Primary emissions	Bag filters	10-20	1-15		<500	300-400
		Advanced ESP	<50	20-40			
		wet waste gas desulphurization				<100	
		SCR					100-120
	Secondary emissions	Bag filters		<10	<0.03–0.05		
		ESP		<30			
Pellet plant	Crushing, grinding, drying		<10	<20			
	Other process steps			<10-15			
	scrubbing or semi-dry desulphurization					<20	
Blast Furnace	BF gas cleaning	Wet ESP / wet scrubber		<10			
	Hot stoves					<200	
	Cast house emissions	Bag filter/ESP		1-15			
BOF plant	Primary dedusting	Dry ESP / bag filter		10-30			
		Wet ESP (existing plants)		<50			
	Secondary dedusting	Dry ESP	20-30	<20			
		Bag filter	5-15	1-10			
EAF plant	Activated carbon + bag filter		<5	<5	<0.05		
	ESP (existing plants)		<15	Not BAT			

The limit values indicated in the two table above are compulsory from 2016. The European Commission supports also the industry's flagship ULCOS programme (Ultra-Low Carbon dioxide (CO₂) Steelmaking)⁷⁷ that involves a consortium of 48 leading players in industry and research, aims to reduce the CO₂ emissions of today's best routes by at least 50%. The first phase of ULCOS had a budget of EUR 75 million and has earmarked four main processes for further development and will be deepened in the next paragraph.

The Commission, furthermore, suggests all policy measures to support the European steel sector to overcome its serious challenges, largely due to global overcapacity. In this context, in 2016 was presented the Communication "Steel: Preserving sustainable jobs and growth in Europe" in which are announced new short-term measures that will strengthen the EU's defence against unfair trade practices, as well as longer-term action to guarantee the long-term competitiveness and sustainability of energy-intensive industries like steel.⁷⁸

- *Defence against unfair trade practices.* The Commission is already imposing a record number of measures to offset the detrimental effect of dumping, with 37 anti-dumping and anti-subsidy measures in place on steel products (16 of which on steel imports from China). Moreover, the EC set to adopt definitive safeguard measures on imports of steel that are intended to shield European steel producers following the trade diversion of steel into the EU market from other producers around the world as a result of the unilateral US measures restricting imports of steel to the American market: the measures concern 23 steel product categories and will take the form of a Tariff Rate Quota (TRQ);

⁷⁷https://setis.ec.europa.eu/system/files/Technology_Information_Sheet_Energy_Efficiency_and_CO2_Reduction_in_the_Iron_and_Steel_Industry.pdf

⁷⁸ http://europa.eu/rapid/press-release_IP-16-804_en.htm



for each of the 23 categories, tariffs of 25% will only be imposed once imports exceed the average of imports over the last three years; these measures are imposed against all countries, with the exception of some developing countries with limited exports to the EU and the European Economic Area (EEA) countries (Norway, Iceland, and Liechtenstein).⁷⁹

- Tackling the causes of global overcapacity. In addition to measures aiming to address global overcapacity, the Commission is tackling the underlying causes of the problem at bilateral and multilateral level with the EU's main partners (China, Japan, India, Russia, Turkey and the United States).
- Investing in future solutions and technologies for a more competitive industry. At EU level, various funds are available to support the steel industry on its modernisation path.
- Modernising the steel industry by investing in people: With the New Skills agenda, the Commission aims to build a shared commitment to invest in people and their skills in close cooperation with Member States and social partners. The European Globalisation Adjustment Fund and the European Social Fund are available to support workers and their local communities, mitigating adverse social consequences in the context of relocation.
- Focused policies in areas like competition, energy, emissions trading and the circular economy will help the steel industry to thrive.

A key role in the policies adopted in the steel industry is held by the World Steel Association (WSA), an international trade association with high public visibility. WSA members represent most of the globe's international steel outputs: it governs its activities by the standards of the strictest and most developed antitrust principles, principally those of the United States and the European Union.⁸⁰

5.3.5.3 Innovation trends in the sector (not from patents and projects)

In order to drastically reduce the overall CO₂ emissions from the production of steel, the development of breakthrough technologies is crucial, some of which have already been mentioned in the previous paragraphs and in this section they will be explained. Today, a large number of promising projects are ongoing in different parts of the world. Some projects are in the early research stage while others are in pilot or demonstration phase. Although their goals are similar, approaches differ and can be categorised as follows:⁸¹

- Hydrogen as a reducing agent: It avoids carbon and uses hydrogen to reduce iron ore thereby averting the creation of CO₂ and producing H₂O (water) instead. Hydrogen already plays a role as a reduction agent in DRI primary steel production, since the methane gas input is first converted to syngas – which is a mix of H₂ and CO – and that syngas then acts as the reduction agent. Existing DRI facilities could therefore be gradually converted to pure hydrogen rather than methane/syngas and steel companies could replace existing BF-BOF plant with newly built hydrogen-based DRI.
- Carbon Capture and Storage (CCS): CO₂ streams can be captured and stored. The process involves retrofitting steel plants with capture technology and requires the development of transportation networks and access to storage sites.
- Carbon Capture and Utilisation (CCU): It uses the components of the co-product gases from existing processes to produce fuels or input material for the chemical industry.

⁷⁹ <http://trade.ec.europa.eu/doclib/press/index.cfm?id=1892>

⁸⁰ <https://www.worldsteel.org/about-us/antitrust.html>

⁸¹ <https://www.worldsteel.org/publications/position-papers/steel-s-contribution-to-a-low-carbon-future.html>



- **Bioenergy:** Using charcoal instead of coal as a feedstock for BF-BOF plants and biogas as an input to DRI production.
- **Electrolysis:** It reduces iron ore using electricity.

The ULCOS programme, mentioned in the previous paragraph, has developed four steel decarbonization processes:⁸²

1. **Top gas recycling blast furnace (TGR BF)** – It is based on the separation of the off-gases so that the useful components can be recycled back into the furnace and used as a reducing agent. Meanwhile, oxygen is injected into the furnace instead of preheated air to facilitate CO₂ capture and storage (CCS). The timeline to complete the demonstration programme is about 10 years, allowing further market rollout after 2020.
2. **Hisarna** – The Hisarna technology combines preheating of coal and partial pyrolysis in a reactor, a melting cyclone for ore melting and a smelter vessel for final ore reduction and iron production. Market rollout is scheduled for 2030.
3. **Gas based reduction** – An advanced direct reduction process with CCS, called ULCORED, that involves the direct reduction of iron ore by a reducing gas produced from natural gas in a shaft furnace. The reduced iron is in a solid state and will need an electric arc furnace to melt the iron. An experimental pilot plant is planned in Sweden, with market rollout foreseen for 2030.
4. **Electrolysis of iron ore** – Two electrolysis variants, ULCOWIN and ULCOLYSIS, which respectively operate slightly above 100°C in a water alkaline solution populated by small grains of ore (electrowinning process), or at steelmaking temperature with a molten salt electrolyte made of a slag (pyro electrolysis). Both are tested at laboratory scale.

After having analysed the decarbonization options of the steel industry, it is possible to assign them a technological maturity, comparing them with conventional options:

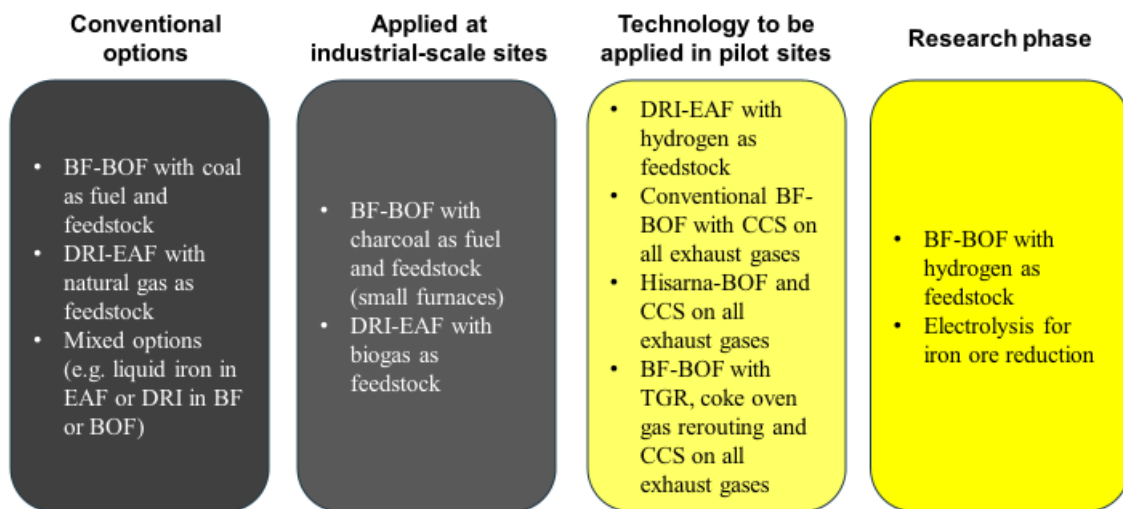

Figure 39. Technological maturity of decarbonization options (source: Energy Transitions)

⁸² "Steel and CO₂ - the ULCOS Program, CCS and Mineral Carbonation using Steelmaking Slag", J.P. Birat, 2011.

5.4 CERAMIC SECTOR ANALYSIS



5.4.1 CERAMIC Market Demand and Supply Analysis

The term ceramics is used for inorganic materials (with some organic content), made up of non-metallic compounds and made permanent by a firing process. In addition to clay-based materials, today ceramics include a multitude of products with a small fraction of clay or none at all. Ceramics can be glazed or unglazed, porous or vitrified.

Firing of ceramic bodies induces time-temperature transformation of the constituent minerals, usually into a mixture of new minerals and glassy phases. Characteristic properties of ceramic products include high strength, wear resistance, long service life, chemical inertness and nontoxicity, resistance to heat and fire, electrical resistance and sometimes also a specific porosity.

Depending on the specific production processes, plants manufacturing ceramic products cause emissions to be released into air, water and land (waste). The environment can be affected by noise and unpleasant smells. The type and quantity of air pollution, wastes and wastewater depend on different parameters. These parameters are, e.g., the raw materials used, the auxiliary agents employed, the fuels used and the production methods.

The size of the overall market was assessed by comparing two different sources, which were found to be similar. The market value of ceramics is estimated at 90 billion in 2018 and will grow with a CAGR of 8.6% until 2030.^{83,84} The major factors driving the market are the rise in use as an alternative to metals and plastics and the growing demand in the medical industry. Asia-Pacific dominated the market across the globe with the largest consumption from the countries of China and Japan.

The electronic and electrical industry dominated the market in 2018 and it is expected to grow during the forecast period. It exploits a wide range of electrical properties of advanced ceramics, including insulating, semi-conducting, superconducting, piezoelectric, and magnetic properties.

Increasing usage in photovoltaic modules, wind turbines, and pollution control applications and increasing applications of silicon carbide and gallium nitride are likely to act as opportunities in the future.

As part of the Ceramic market, the global tiles market is driven by the growth in the construction industry, owing to rapid expansion of the housing sector and increase in construction spending globally. Urbanization

⁸³ <https://www.grandviewresearch.com/industry-analysis/advanced-ceramics-market>

⁸⁴ <https://www.alliedmarketresearch.com/ceramic-tiles-market>

and increase in population are expected to fuel the market growth. Ceramic tiles provide an aesthetic look, sustainability, and better reliability, leading to increased demand in construction of large number of buildings. The global ceramic tiles market growth is characterized by numerous opportunities to market players, owing to rise in disposable income and rapid growth in the global economy.

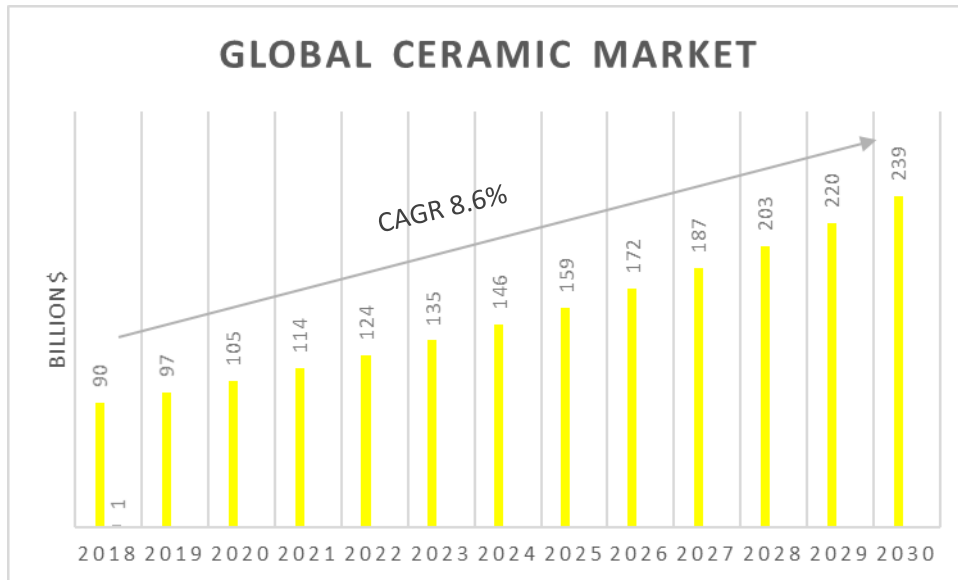

Figure 40. Global Ceramic Market

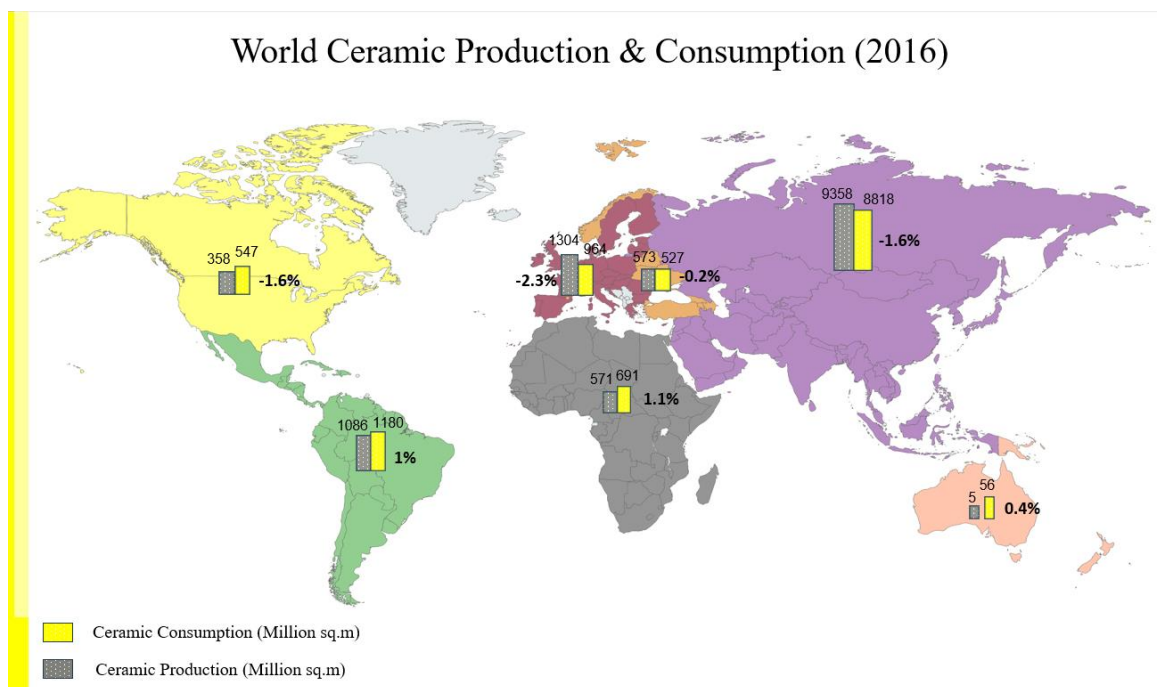

Figure 41. World Ceramic Production and Consumption^{85,86}

⁸⁵ Source: Acimac “World Production And Consumption Of Ceramic Tiles”

⁸⁶ Source: Ceramic World Review “Tecnargilla & Cersaie 2018”



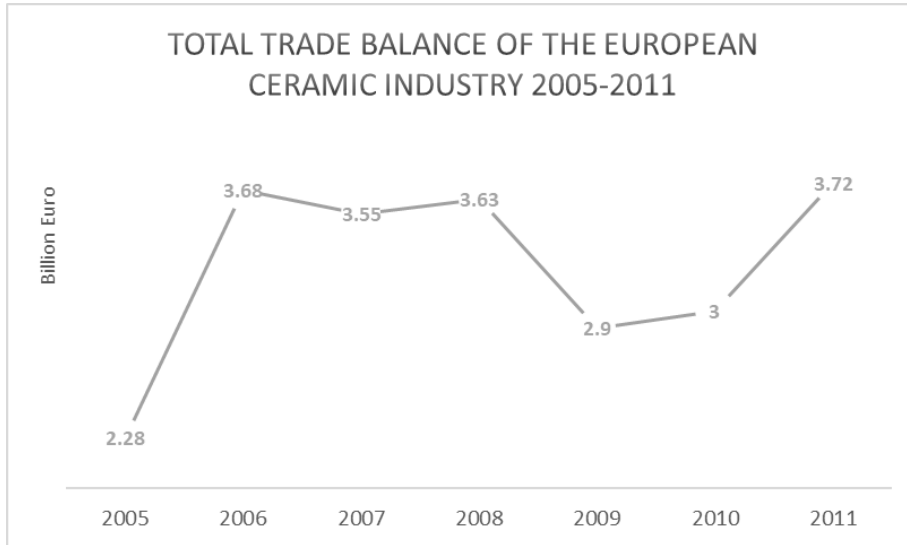

Figure 42. European Ceramic market⁸⁷

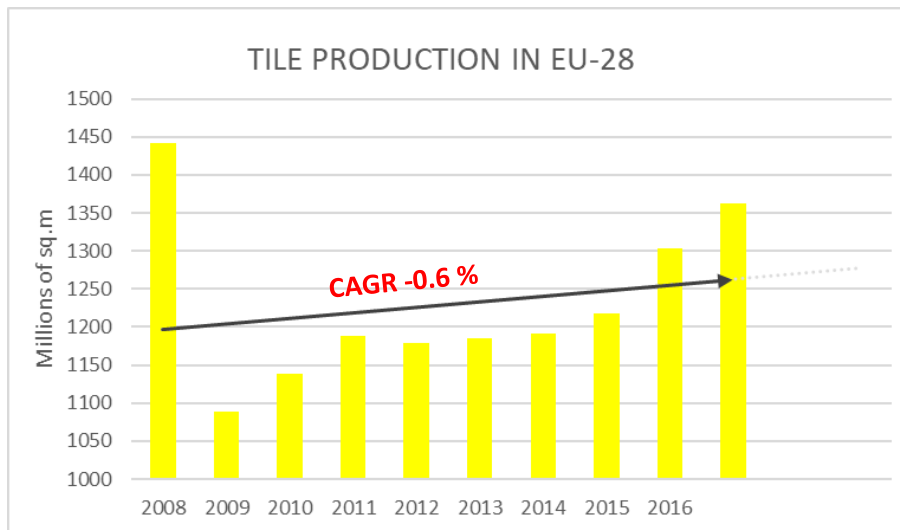

Figure 43. Tile production (EU-28)

The European ceramic industry is structured in sector ranging from construction products and consumer goods to industrial processes and cutting-edge technologies⁸⁸.

- Wall and floor tiles
- Bricks and roof tiles
- Refractories
- Technical ceramics
- Tableware
- Sanitaryware
- Abrasives
- Clay Pipes

⁸⁷ https://www.ceramfed.co.uk/uploads/popular_downloads/04ed1d019530eec2cfe5fd2f4e174a19bbd363ae.pdf

⁸⁸ <http://cerameunie.eu/ceramic-industry/facts-figures/>



The EU Ceramics Industry is a world leader in producing high quality ceramic products such as tiles, bricks, sanitary ware, or vitreous clay pipes. The ceramic tile industry constitutes the biggest sub-sector in terms of turnover among European general ceramic industries and is closely linked with the enamel frits, glazes and ceramic colours manufacturers. Ceramic colours are preparations made of frits, ceramic pigments and inorganic raw materials. Together with enamels, colours are the main components of the ceramic tile surface. Pigments are used to provide colour solutions for several sectors like plastics, paint, construction materials, and cosmetics industries, as well as other industrial markets. The global pigments market was worth \$12.7 billion in 2015, and it is anticipated to grow at a compound annual growth rate (CAGR) of 4.5% through 2024.⁸⁹

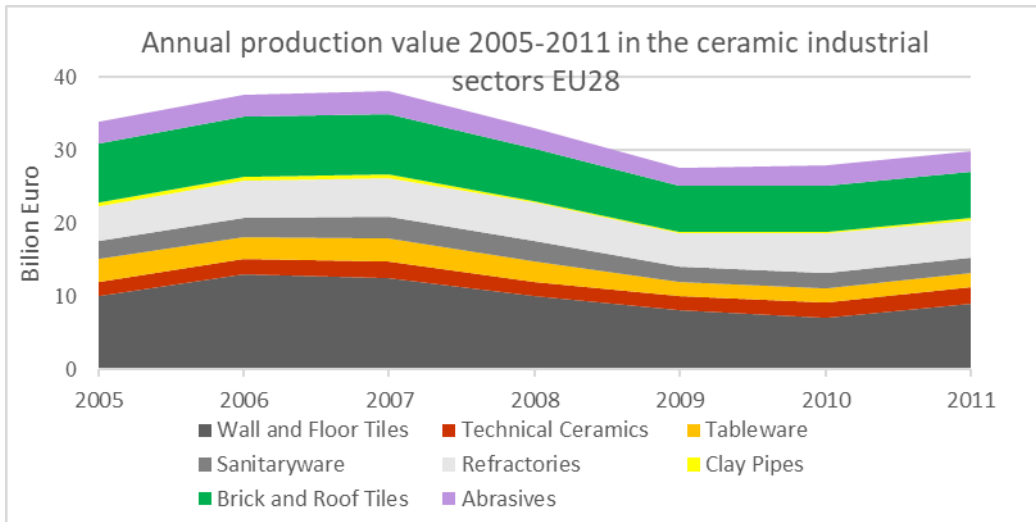

Figure 44. Ceramic industrial sectors production

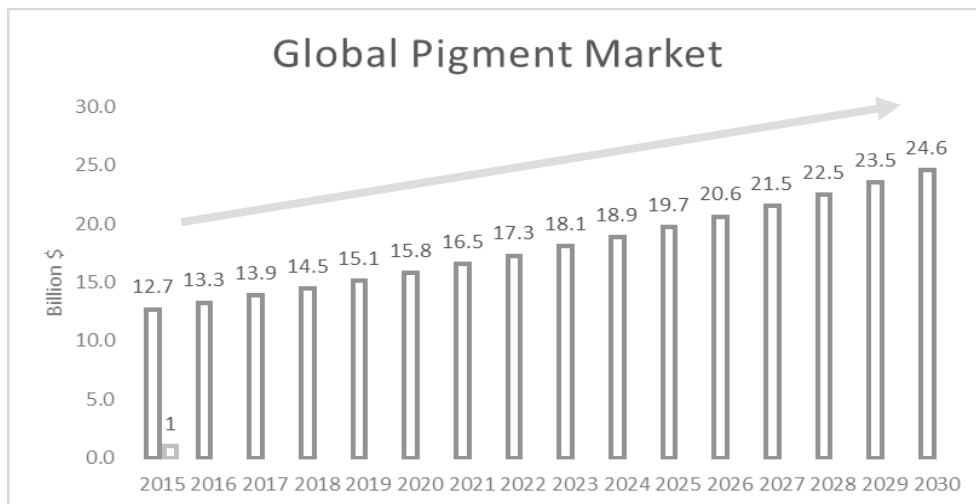

Figure 45. Global Pigment market

⁸⁹ https://www.inkworldmagazine.com/issues/2017-03-01/view_features/the-2017-pigment-report/



5.4.2 CERAMIC and PIGMENT Industry Key Players

5.4.2.1 Key Countries

Leading the way in innovation and technology, ceramic manufacturers from the EU-28 account for 23% of global ceramics production. With a production value in Europe of €28 billion, the leading Member States producing ceramics are Italy, Germany, Spain, France, the UK, Poland, Portugal and Austria. Ceramic manufacturing is present in virtually all EU Member States.

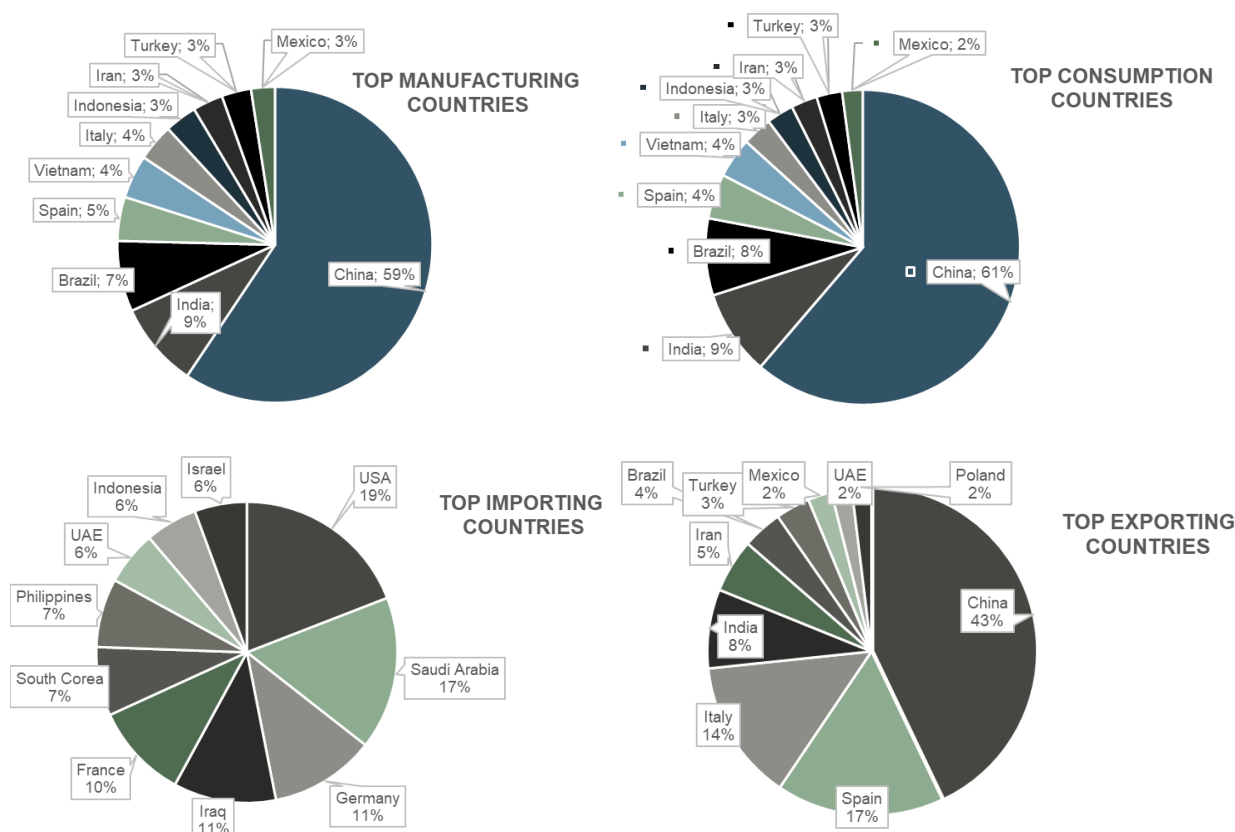

Figure 46. Top countries

The ceramic sector makes a positive contribution to the trade balance of the EU. Around 25% of EU-28 production is sold outside the EU, representing a positive input to the balance of trade. Total exports in 2011 were €7.2 billion while imports were €3.5 billion. This trend is on the increase with 2011 exports increasing by 7.3% and imports decreasing by 5.9% compared to 2010.

Fixed around 30%, energy remains one of the highest production costs in the European ceramic industry, where the energy mix is around 85% natural gas to 15% electricity. Over 1,000 ceramic installations are covered by the EU Emissions Trading Scheme (ETS), representing more than 10% of all industrial installations covered by the scheme

Asia is the largest regional geographic market for Pigments. It consumed 87,136 tonnes in 2018 and be worth \$2.36 billion. In contrast to Asia, Europe will have a value of \$2.11 billion; though it will continue to lead demand for some High Performance Pigments (HPPs), like metallics. After overcoming the negative impact of geopolitical tensions in 2014 and 2015, especially in Eastern Europe, the market resumed stability in 2016

supported by stronger EU consumer spending, investments in infrastructure and housing development, and the healthy growth of the automotive sector in many European countries.

European consumption of HPPs will top 75,000 tonnes for the first time in 2018, almost a fifth of these are complex inorganic coloured pigments (CICPs). Moderate growth will push this figure to 84,301 tonnes in 2023 with demand especially strong for CICPs. The European market for pigments continues to experience different growth patterns and drivers. Germany is the largest national market for HPPs in Europe, with a 30.8% share by tonnage, followed by Benelux where with a 19.6% share. Germany's market share will increase to across 2018-2023 to 31.2%; but the highest growth rates will be seen in the less mature markets of Russia and other Eastern European states. With Russia still importing around 80% of its HPPs the country represents a key strategic priority for suppliers in Western Europe⁹⁰.

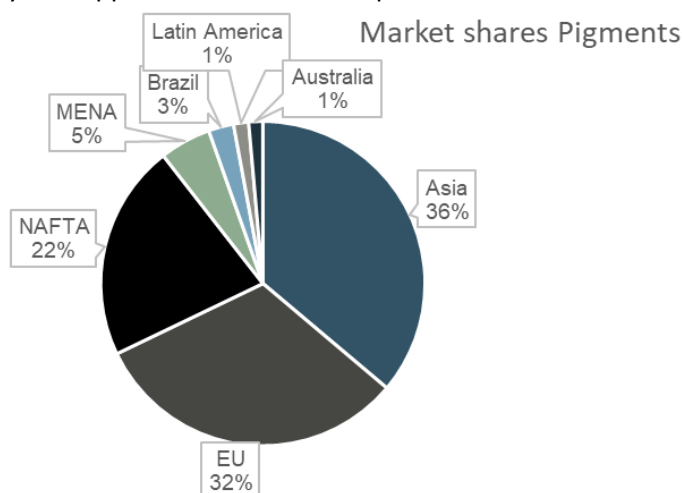

Figure 47. Market shares Pigments

The European ceramic sector is highly concentrated: In 2014, Spanish and Italian producers together sold more than 78% of all ceramic wall and floor tiles in the EU, but the data show that ceramic industry is competing on a global scale.

For example, it suffered during the last economic crisis in Europe due to drop in constructions, and between 2008 and 2013, total sales dropped by 23% from €12,259 million to €9,399 million. Yet, in the same period sales outside the EU increased: from 27% in 2008 to 39.2% in 2013.

Ceramic is an Energy Intensive industry: many European ceramics producers keep plants out from Europe (i.e. Russia or USA) for a cheaper cost of energy (e.g. in Russia, natural gas prices are ca. 78% cheaper than the average price in the EU). As told, energy usually accounts for around 25-30% of total production costs, even if this strongly depends on fuel prices, and the externalities behind them (e.g. political stability and policies).

More specifically, wall and floor tile production require the use of a significant amount of thermal energy, employed mainly in three stages: firing (55%), followed by spray drying (36%) and drying (9%).

⁹⁰ <https://www.smithersrapra.com/resources/2018/july/global-outlook-for-high-performance-pigments>

5.4.2.2 Key Players

Tiles: Rankings of the top 26 world groups, the positions of the 3 largest tile producers keeps remaining unchanged.

- **The American giant Mohawk Industries, Inc.** remains firmly at the top of the rankings with an estimated 2017 output of between 230 and 250 million sq.m. The US multinational is well ahead of all its competitors, especially in terms of revenues. As of 31/12/2017, it reported sales of US \$3,405 billion in the tile segment alone, equivalent to 36% of the group's total revenues.
- **The Thai group SCG** is in second place in terms of output volumes (187 million sq.m), but well behind in sales revenues (709 million euros).
- **The Mexican group Lamosa** increased its tile production to 171 million sq.m and registered revenues at 751.4 USD million (about 647 million euros). We remind that Lamosa strengthened its position as the third largest world group and the leader in Latin America following the acquisition of the Argentinian group San Lorenzo on 3 October 2016, with manufacturing facilities in Argentina, Colombia and Peru⁸⁶

Pigments: According to Nexant⁹¹, Clariant and BASF are global, leading and well-established pigment producers and are focused on organic pigments and dispersions for all major end-markets: e.g. inks, coatings and polymers, yet, they are each quite different pigments companies – based on pigment portfolio and end-market focus.

In fact, BASF portfolio also brings with it a palate of CCIPS and pearlescent pigments which were acquired from its Engelhard acquisition back in 2006. From its acquisition of Ciba in 2009, BASF also acquired a larger portfolio of organic pigments. The end-market focus of both businesses also varies due to inter-company relationships. Clariant Pigments has a strong offering in polymers due its masterbatch business while BASF is more focused on coatings (particularly automotive coatings) where it is also active.

Pigments market structure

Selected producers	Pigments produced		
	Inorganics	Organics	Specialities
Clariant		■ ■ ■ ■	■ ■
BASF	■ ■	■ ■ ■ ■	■ ■ ■ ■
DIC (incl. Sun Chemical)	■	■ ■ ■ ■	■ ■
Heubach	■ ■	■ ■ ■ ■	■ ■
Ferro	■ ■ ■ ■	■	■ ■
Venator (ex Huntsman)	■ ■ ■ ■		■ ■
Lanxess	■ ■ ■ ■	■	■
Altana (Eckart)	■		■ ■ ■ ■
Sudarshan (India)	■	■ ■	■
Meghmani Organics (India)		■	
Changzhou North American Chemical Group (China)		■ ■	
Lily Group (Hangzhou Baihe Chemical) (China)		■ ■	

Figure 48. Pigments Key Players⁹¹

⁹¹ <https://www.nexant.com/resources/organic-pigments-landscape-challenges-producers-clariant-and-basf>



5.4.3 CERAMIC and PIGMENT Sector Description:

5.4.3.1 Employment & global turnover

The European ceramic industry today employs over 200,000 people in the EU-27, around 80% of them in SMEs. World-leading companies are headquartered in the EU and the industry develops highly skilled and trained employees.

Almost 60% of jobs in the industry are related to the housing and construction sectors, sectors with an important historical legacy in many European countries and which continue to contribute positively to the local economy. Housing and construction represented almost 55% of the ceramic industry's turnover in 2011 and supplies to other industries account for more than 30%⁹².

5.4.3.2 Process Routes

The ceramic processing can be divided into three main steps: *powder processing*, *shaping*, and *firing*. Brick manufacturing typically includes raw-materials shipping and storing before use. As logistics can of course impact on costs, clustering is a good practice, and brick manufacturers are generally located near clay deposits. For a brick formulation, one or more clays are needed.

The raw materials are ground and/or mixed in pug or roll mills. Bricks are then shaped by extrusion from pastes, whereas for roof tile forming, uniaxial pressing is applied to a plastic body using different die designs for several shapes and sizes. After shaping, excess moisture is evaporated by natural or forced drying. Finally, firing is performed in intermittent kilns (mostly) or tunnel kilns (in modern brick plants). After firing, the products are inspected, packed, and stored for later shipping. Gases originating from raw material decomposition or burning out of organic matter and additives are released during the firing schedule before the bodies are densified by sintering⁹³.

Electric power is needed by almost all process. It is required by mechanical equipment, such as mills, presses, extruders, and glazing machines, as well as for heating as dryers and kilns need electric power. Particularly in firing processes, heat is usually generated from fossil fuels. These can be solid (such as coal or biomass), liquid (such as liquefied petroleum gas (LPG)), or gaseous (such as natural gas (NG)). Excess heat from hot gas emissions, may be eventually recovered for drying or preheating purposes, increasing energy efficiency.

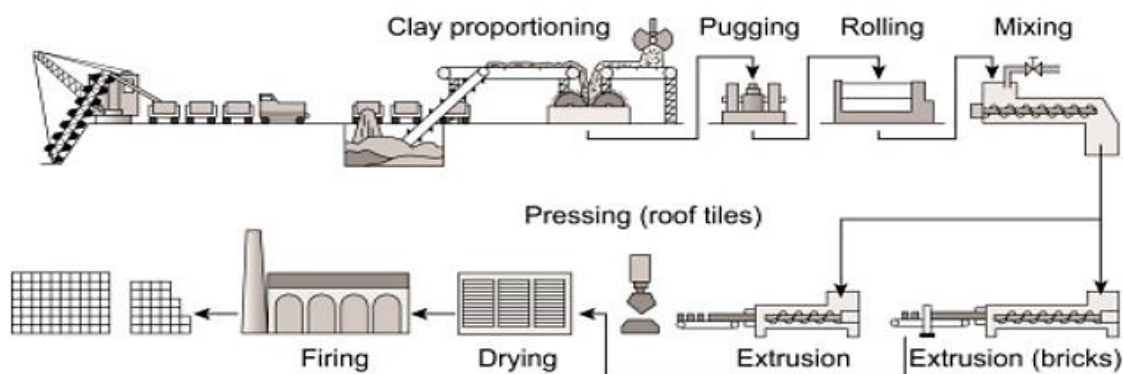

Figure 49. Ceramic brick process⁹³

⁹² https://ec.europa.eu/growth/sectors/raw-materials/industries/non-metals/cement-lime_en

⁹³ <https://www.sciencedirect.com/topics/materials-science/ceramics-processing>

Pigment processing: Inorganic pigments for the colouring of ceramics are produced through a reaction to the solid state at high temperatures (700°-1400°). Below, all types of inorganic, organic and special pigments are reported and associated to the field of application.

Pigment type	Main applications						Global demand outlook (vs. GDP)
	Architectural paints	Industrial coatings	Automotive coatings	Plastics	Inks	Other	
INORGANICS							
TiO ₂	■■■	■	■	■■	■	■ Personal care	→
Carbon black	■	■	■	■	■	■■■ Rubber tyres	→
Iron oxides	■■	■■	■	■	■	■ Cosmetics ■■■ Concrete	→
Zinc oxides	■	■	■	■	■	■ Personal care	→
Ultramarine	■	■	■	■	■	■ Cosmetics	→
Mixed metal oxides	■	■■	■	■■	■	■■■ Ceramics	→
ORGANIC							
Azo pigments	■■	■	■	■■	■■■	■	→
Polycyclic pigments	■■	■■	■■	■■	■■	■	→
SPECIAL EFFECT PIGMENTS							
Effect pigments (pearlescent etc.)	■	■■	■■■	■■	■	■■■ Cosmetics	→
Functional pigments (e.g. anti-corrosion)	■	■■■	■	■	■	■ Electronics	→

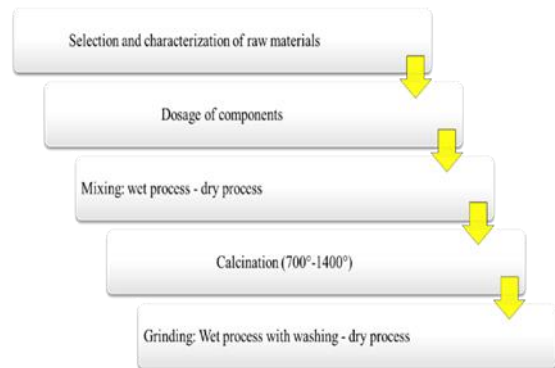

Figure 50. Pigment type and processing

Pigments are largely sold as dry powder (e.g., approximately 70% of Clariant sales volumes). These pigments are then formulated as dispersions with other additives.

- Coatings (in the form of paints and inks) are the largest market for colour pigments, representing more than half of demand.
- Other applications depend on the type of pigment but include higher volume concrete, ceramics and other building materials, plastics as well as lower volume but higher value cosmetics and other high-purity applications.

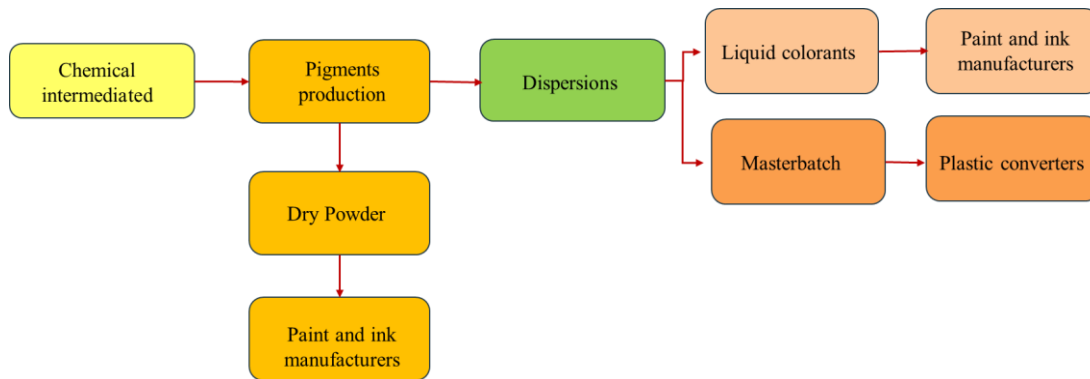

Figure 51. Pigment Value chain

5.4.3.3 Cross-sectoral Value-chains

The ceramic industry is a complex network of businesses, mixing vertical and horizontal value-chains (supply relationships and collaborative ones). Companies that produce ceramic tiles, needs materials supply from producers of raw materials, glazes and inks and technology providers (manufacturers of machinery and equipment). Numerous service companies are also needed (if not integrated into the company): e.g. graphic studios for decorations; end-of-line processing to finish the final product with cuts, grinding and lapping; display systems producers for the exhibition rooms and the sales points and of course suppliers of logistical services.

Distribution channels are either direct sales network of the ceramic manufacturer (commercial agents), or intermediaries that only deal with distributors. Distributors and retailers work with construction companies, suppliers of glues and adhesives for tile laying, architects and designers to meet the expectations of end



customers. By looking at the flow of materials in their path of transformation into ceramic tiles, we can see this network of economic agents as an efficient supply chain that can also create value for the end customer. In fact, each operator belonging to the supply chain creates value in the network thanks to the collaborative relationships between technology and material suppliers and tile manufacturers in an open innovation environment that increases the competitiveness of individual companies and the entire ceramic sector.

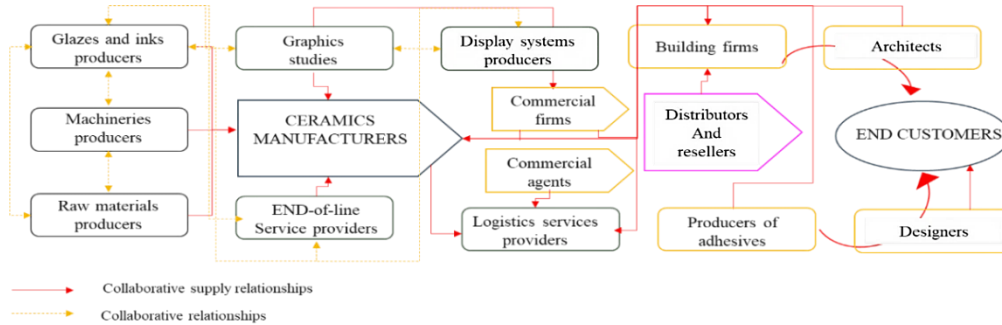

Figure 52. Ceramic Tiles Value chain⁹⁴

5.4.3.4 Used Technologies

There are two types of kilns for firing pigments. The first is the rotary kiln (adapted for firing pigments) similar to the concept used for cement, and the other is the innovative vertical kiln.

However, there are other processes currently being tested for pigments firing, that have the potential to reduce emissions and save energy. The following table lists these new pigment firing technologies with the advantages and disadvantages compared to traditional technology.

Type of Kilns	Advantages	Hindrances
Rotary Kiln	<ul style="list-style-type: none"> Fast firing cycles (< 1h) Higher temperature Energy savings Higher automation 	Open system: <ul style="list-style-type: none"> Reduced effect of mineralisers No efficient fluid mass transport Possible just where: <ul style="list-style-type: none"> Solid state reactions predominant Reactions kinetics is fast
Vertical Kiln	<ul style="list-style-type: none"> Fast firing cycles (< 1h) Higher temperature Energy savings Higher automation 	
Fireless Processes	Advantages	Hindrances
Microwave	<ul style="list-style-type: none"> Energy savings Low temperature Better control on synthesis Better control on particle size 	<ul style="list-style-type: none"> Slow kinetics Uncomplete reactions Too fine particle size distribution Accelerate dissolution in glazes
Mechanosynthesis Milling of raw materials inside a very high energy mil (vibratory, planetary, attritor) for long time. The final phase composition is achieved without firing, but only through mechanical alloying	<ul style="list-style-type: none"> Easy processing No investment for kiln and refractory furniture Fulfilment of particle size requirements 	<ul style="list-style-type: none"> Many impurities from grinding media Low productivity (low bulk density powders) Difficult control of particle size distribution
Hydrothermal	<ul style="list-style-type: none"> Easy processing No investments for kind and refractory furniture Fulfilment of particle size requirements 	<ul style="list-style-type: none"> More expensive raw materials Time consuming complex treatments Large amount of fluid effluents Need of consistent plant investment

Figure 53. Type of kilns and Fireless processes⁹⁵

⁹⁴ https://www.researchgate.net/publication/329043512_Lifecycle-oriented_design_of_ceramic_tiles_in_Sustainable_Supply_Chains_SSCs

⁹⁵ SOURCE: INNOVATION IN CERAMIC PIGMENTS Institute of Science and Technology of Ceramic Materials



5.4.4 CERAMIC and PIGMENT Industry Externalities (completing a PESTLE analysis)

5.4.4.1 Environmental and Societal Impacts

Ceramic in general is subject to ETS as intensive emitting industry. Indeed, the bricks and roof tiles, refractories and wall and floor tiles sectors together emitted a total of 19 Mt CO₂ in 2010. Of these emissions, 66% were due to fuel combustion, with electricity and process emissions accounting for 18% and 16% respectively⁸⁷.

Literature values of specific emissions for the conventional production of ceramic pigments (CP), (assuming natural gas providing 1.5 kWh of thermal demand for producing 1 kg of CP):

In the last two decades, significant reductions in energy consumption have been made during production, for example, through better kiln design and more efficient firing. Energy-saving innovations and materials technology have focused mainly on replacing solid fuel with natural gas, scaling up and improving the efficiency of kiln technology, and moving, where appropriate for the scale of operation, from intermittent (batch) to continuous (tunnel or fast-fire roller kiln) technology. The ceramic industry is continuously improving its energy efficiency where economically viable. The energy used to produce the bricks for a 1m² brick wall decreased by 39% from 1990 to 2007. For one tonne of wall and floor tiles, the energy used decreased by 47% from 1980 to 2003. By changing from a twice-fired process at conventional firing temperatures to a single firing process at reduced firing temperatures, one UK hotel tableware producer reduced emissions by 79% compared with similar products. High-performing and durable ceramics must be fired at high temperatures. As such, the most energy-intensive process in ceramic manufacturing is kiln firing and, in some cases, the drying and shaping processes.

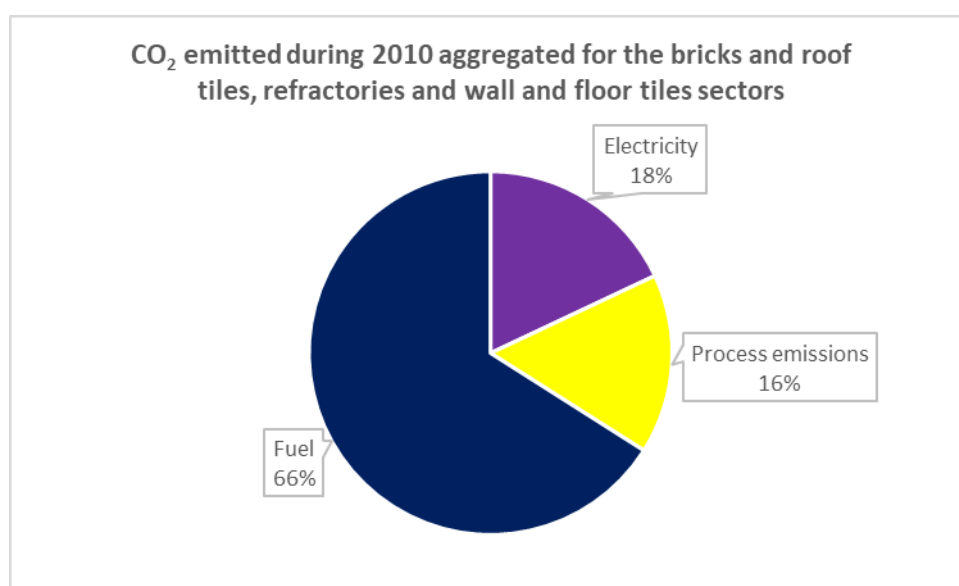

Figure 54. CO₂ emitted during 2010

A general approach of CO₂ reduction starts with the identification of the main processes of emissions and after that through good knowledge of processes and energy consumption try to reduce emissions. Through results shown in the figure (Figure 45), firing and spray drying are the main processes of CO₂ emissions and during these two processes 83% of CO₂ are emitted.

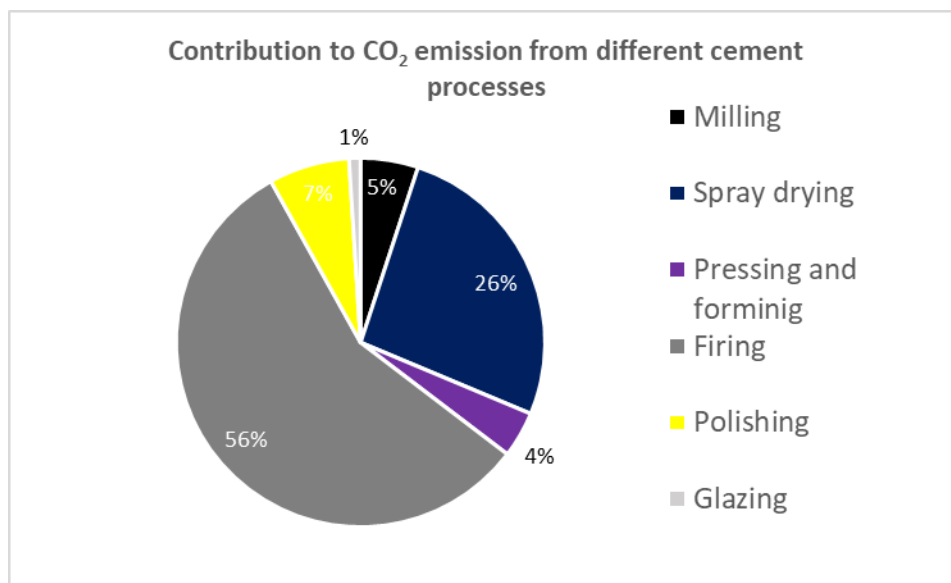

Figure 55. CO₂ Cement process.⁹⁶

The ceramics industry produces a large variety of different products for different applications.

Sub-sector	Production (Mt)	Specific energy consumption (GJ/t)	Energy consumption (TJ)	Relative share of energy consumption
Bricks and roof tiles	55	238	130.9	38%
Wall and floor tiles	25	5.74 ¹	143.5	42%
Refractory products	4.5	5.41	24.345	7%
Sanitary ware	0.5	20.88	10.44	3%
Vitrified clay pipes	0.7	6.10	4.27	1%
Table- and ornamental ware	0.5	43.46	21.73	6%
Technical ceramics	0.15	34.72	5,208	2%
Expanded clay aggregates (2002)	3.0			
Inorganic bonded abrasives (2003)	0.04			
Total			340	100%

¹ Cerame Unie indicated that this figure only includes drying and firing

Figure 56. Specific consumption for different sectors⁹⁷

⁹⁶ Source: CO₂ Emission Calculation and Reduction Options in Ceramic Tile Manufacture-The Foshan Case

⁹⁷ https://ec.europa.eu/clima/sites/clima/files/ets/allowances/docs/bm_study-ceramics_en.pdf

5.4.4.2 Policy Relevant Standards and Directives

The BAT98 Reference Document (BREF) entitled 'Ceramic Manufacturing (CER)' reflects an information exchange carried out under Article 16(2) of Council Directive 96/61/EC (IPPC Directive).

Depending on the specific production processes, plants manufacturing ceramic products cause emissions to be released into air, water and land (waste). Additionally, the environment can be affected by noise and unpleasant smells. The type and quantity of air pollution, wastes and waste water depend on different parameters. These parameters are, e.g. the raw materials used, the auxiliary agents employed, the fuels used and the production methods:

- **emissions to air:** particulate matter/dust, soot, gaseous emissions (carbon oxides, nitrogen oxides, sulphur oxides, inorganic fluorine and chlorine compounds, organic compounds and heavy metals) can arise from the manufacture of ceramic products.
- **emissions to water:** process waste water mainly contains mineral components (insoluble particulate matter) and also further inorganic materials, small quantities of numerous organic materials as well as some heavy metals.
- **process losses/waste:** process losses originating from the manufacture of ceramic products, mainly consist of different kinds of sludge, broken ware, used plaster moulds, used sorption agents, solid residues (dust, ashes) and packaging waste.
- **energy consumption/CO₂ emissions:** all sectors of the ceramic industry are energy intensive, as a key part of the process involves drying followed by firing to temperatures of between 800 and 2000 °C. Today natural gas, liquefied petroleum gas (propane and butane) and fuel oil EL are mainly used for firing, while heavy fuel oil, liquefied natural gas (LNG), biogas/biomass, electricity and solid fuels (e.g. coal, petroleum coke) can also play a role as energy sources for burners.

The table shows BAT emission levels for gaseous inorganic compounds from flue-gases of kiln firing processes by applying a combination of primary measures/techniques and/or secondary measures/techniques.

Parameter	BAT-associated emission level (mg/N m ³)
HF	1-10
HCL	1-30
SO ₂	500-2000
DUST	1-20

Figure 57. BAT emission level

The ranges depend on the content of the pollutant (precursor) in the raw materials, i.e. for firing processes of ceramic products with a low content of the pollutant (precursor) in the raw materials, lower levels within the range are BAT and for firing processes of ceramic products with a high content of the pollutant (precursor) in the raw materials, higher levels within the range are BAT AELs.

The higher BAT level can be lower depending on the characteristics of the raw material.

The higher BAT level can be lower depending on the characteristics of the raw material. Also, the higher BAT AEL should not prevent the re-use of waste water. The higher BAT level only applies to raw material with an extremely high Sulphur content.

⁹⁸ https://eippcb.jrc.ec.europa.eu/reference/BREF/cer_bref_0807.pdf



5.4.4.3 Innovation trends in the sector

Energy Efficiency in Production In the last two decades, significant reductions in energy consumption have been made during production, for example, through better kiln design and more efficient firing. Energy-saving innovations and materials technology have focused mainly on replacing solid fuel with natural gas, scaling up and improving the efficiency of kiln technology, and moving, where appropriate for the scale of operation, from intermittent (batch) to continuous (tunnel or fast-fire roller kiln) technology. The ceramic industry is continuously improving its energy efficiency where economically viable.

Fuel Emissions - Energy efficiency is the most obvious way to reduce fuel emissions. Energy consumption can be further reduced if improved kilns, dryers, thermostats and seals are installed and by implementing automated controls. Heat savings can be achieved by improving thermal insulation through the use of novel refractory linings, coatings and other ceramic materials. As the life of a kiln can be more than 40 years and represents major capital investment, it is not financially-feasible to routinely upgrade kilns before the end of their life and replace them with more energy-efficient models. Recovery of excess heat is also widespread as it reduces fuel consumption. This can be done by capturing kiln gases in order to preheat the combustion or dryer air. Smart design of manufacturing facilities is also a key factor because the physical distance between the different processes, e.g. firing and drying, can account for energy savings. Electrification of kilns using low-carbon electricity could be an option to reduce fuel emissions, particularly for large kilns making bricks, roof tiles, wall and floor tiles. However, this option is not currently economically-viable due to the significantly higher cost of power compared to natural gas.

Alternative Energy Sources - The continuous processes used in the ceramic industries all require uninterrupted, secure and affordable fuel and electricity supplies as unplanned interruptions can cause severe kiln damage resulting in shutdown and production loss for several months.

The ceramic industry predominantly uses natural gas as it is more energy efficient at the high temperatures required to fire clay and other industrial minerals. Today, diesel, LPG, coal or coke are only used when mains gas is unavailable. Across Europe, companies are now integrating alternative fuels and renewable electricity into their energy mix. Several countries have started using renewable energy for some brick, roof tile and clay pipe sites, but have encountered difficulties in obtaining planning permission for some of these installations, particularly for wind turbines and energy from waste projects. Therefore, a favourable legal framework is essential for waste to energy projects. Cogeneration has developed in Member States where there are clear regulatory incentives for combined heat and power (CHP) generation. In 2012, there were around 250 CHP plants mainly in Italy, Portugal and Spain with an average installed capacity of 3MW. Many are micro-generation facilities with less than 1MW capacity. By producing electricity in addition to the heat necessary for its low to medium-temperature needs, the ceramic industry contributes to the overall energy efficiency of these Member States.

Process Emissions - Carbon dioxide emissions are not only related to energy consumption, e.g. fuel-related emissions, but also to process emissions. Process emissions are carbon dioxide emissions caused by the breakdown of carbonates in raw materials such as limestone, dolomite or magnesite. As these are inherent in the raw material, these process emissions are a natural by-product of the firing process and cannot be avoided. The amount of process emissions from clays differs depending on the composition of the minerals and the local geology. The use of locally-available raw materials avoids long-distance transportation and consequently higher CO₂ emissions. As such, it would not be environmentally-sound to relocate factories and jobs to reduce process emissions.



CCS - Carbon Capture and Storage (CCS) could be a solution to reduce CO₂ emissions in some sectors. However, ceramic factories are more numerous, smaller in size and more widely-dispersed geographically than, for example, those in the steel and cement sectors. The exhaust stream from ceramic plants is too CO₂ dilute, too hot and contains too many other substances for efficient, cost-effective CCS at present. Until cost-effective breakthrough CCS technology is developed on an appropriate scale for the ceramic sector, the installation of CCS is likely to remain prohibitively expensive for some time after it is installed in other energy-intensive sectors.

Emissions Related to Electricity Consumption - The ceramic industry is not classed under the EU ETS as electro-intensive so it does not benefit from any electricity pass-through compensation. For some of the high-temperature processes in the refractories and technical ceramics sectors, such as electric arc furnaces and electric induction furnaces operating above 2000°C, there is a significant risk of carbon leakage outside Europe. However, the electro-intensity of the ceramic sector is expected to rise towards 2050 as some processes may shift from gas to electric firing. Moreover, increasing demands under the EU Industrial Emissions Directive and other legislation may require more use of electrically powered equipment. Therefore, some ceramic sectors will have significantly more electricity usage and may therefore become vulnerable to job and carbon leakage as they are highly exposed to international trade.

Technologies	Available today	Pilot only	Requires Significant Development	Breakthrough Technology
<i>On-site CHP</i>	█			
<i>Process optimisation</i>	█			
<i>Energy management</i>	█			
<i>Raw materials formulation changes for more efficient firing</i>	█			
<i>New kiln design</i>	█			
<i>Clay/raw material preconditioning</i>		█		
<i>Heat exchanger in kiln stack</i>		█		
<i>Low-temperature heat recovery from kiln exhaust</i>			█	
<i>On-site syngas and biogas</i>			█	
<i>CCS</i>				█

Figure 58. Technological innovation trends⁸⁷

The push to decarbonize electricity in Europe will reduce the ceramic industry’s indirect emissions from electricity but will not be sufficient to adequately decrease its emissions by 2050. Most emissions in ceramic production arise from fuel and more radical steps and breakthrough technologies are required. There also remains the major challenge of process emissions reduction in some sectors. The cost of adaptation will significantly affect the global competitiveness of the ceramic industry.



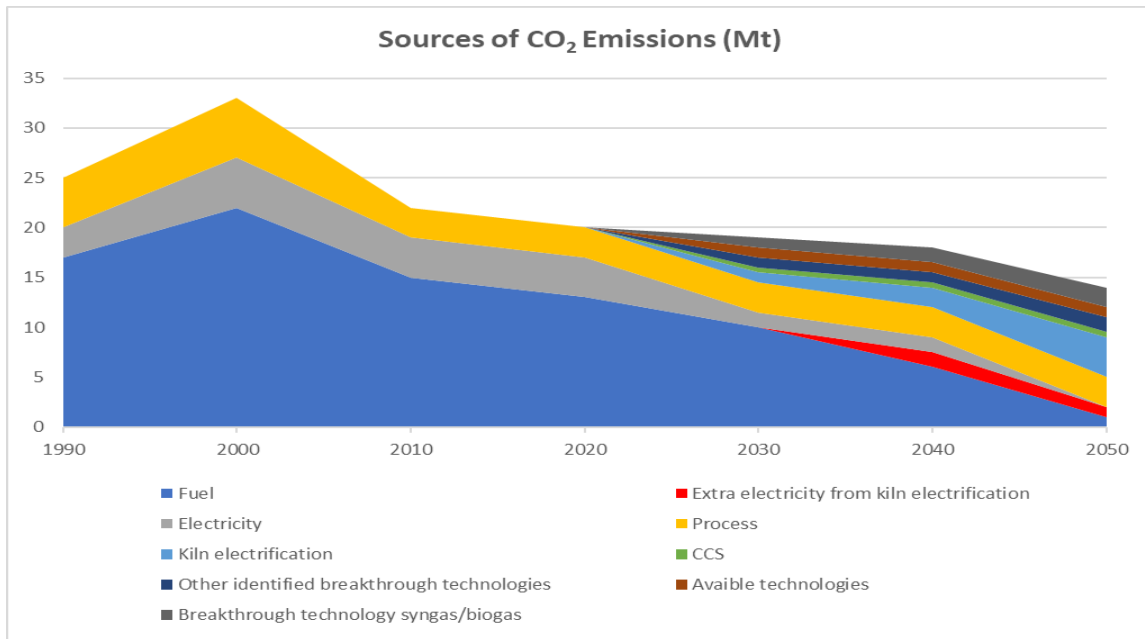

Figure 59. CO₂ emission reduction between 2010 and 2050

The Cerame-Unie emissions reduction model assumes a constant level of production between 2010 and 2050 with a similar product mix and that the emissions are for constant and near-full kiln load and production levels. It should also be noted that the lower 2010 level of production is affected by the consequences of the economic crisis⁸⁷.

6 PROJECT POSITIONING – PRELIMINARY ANALYSIS

DESTINY aspires to introduce the “first-of-a-kind” high temperature microwave processing system at industrial level, offering a variety of vital benefits to energy intensive sectors: reduced energy consumption, lower lifetime operating costs and enhanced sustainability profile.

As main product, DESTINY will release a container-size mobile microwave-powered plant targeted to 3 energy-intensive sectors working on solid materials: cement, steel and ceramic. The project proposes to exploit fluidized bed transport, microwave heating and real-time process monitoring and control for calcination of new pop calcined clay for low clinker cement (cement sector), intermediate steel and zinc product from recycling (steel sector), and high added value ceramic pigments (ceramic sector).

	CERAMIC	CEMENT	STEEL
Product	Pigment	Calcined Clays	Pig iron and zinc recycling
SECTOR	Ceramic	Cement	Steel
Temperature (°C)	1000	750	1000
PROCESS	Calcination	Dehydroxilation	Roasting
Microwave absorption capacity	Moderate absorber	Very low absorber	Good susceptor
SYSTEM	Fluidised bed/rotary	Fluidised bed	Fluidised bed/rotary
Current TRL	4	4	4
Final TRL	6	6	6
Target for validation in DESTINY	20 kg/h	20kg/h	10kg/h
Capacity at industrial level per MW cell*	130 kg/h	130 kg/h	67 kg/h
Number of cells per module (rate 1t/h)*	8	8	15
DEMO SITE	KERABEN	KERABEN	DK
Industrial end-user	ALFARBEN	CEMEX	DK

*referred to standardised 100 kW power generator were DESTINY will be focused.

Figure 60. Project Pilots concept

At the core of DESTINY’s Value Proposition there is a new MW-based kiln concept. On top of the MW-kiln, DESTINY’s main exploitable results were identified as:

- ⇒ **Plant Technology:**
- ⇒ **ECO-Products and on-site services:** new and customized high added value products making it possible to adjust production to low volume demanded amounts using portable facilities.
- ⇒ **Derived Technical Solutions:** solutions for controlling and Virtual Sensors for microwave systems can be offered to laboratories or industrial customers related to microwave treatment of materials.
- ⇒ **Expert training:** Research and academic institutions within DESTINY will take advantage of the knowledge created, in order to establish, train and explore a network of broker consultants to offer as a service to industry

At proposal stage preliminary business cases were already presented both for cement and ceramic. As a summary:

- **CERAMIC:** the project will generate a new family of ECO-PIGMENTS with a significant reduction in the embodied content of CO₂, following a cut in energy needed per kg for heating and transporting (i.e. loading, moving raw materials) by 50% [kWh/kg] and a payback time for the technology decreased by 23%.
- **CEMENT:** a new formulation (15% Calcined clay, 85% Clinker) will be tested to define a new ECO-CEMENT based on CC and with a 11% decrease (or a similar for worst cases) of the payback time for a kiln investment. The average thermal energy consumption [kWh/kg] is cut by 64%. Again, a small



price increase for the final product can be justified with the ECO character and the on-site production business model allowed by the container size of the DESTINY units.

- STEEL:** DESTINY Microwave Kiln technology aims to produce steel intermediate products, such as pig iron and zinc by-products, to feed the final steelmaking technologies (EAF and BOF). Yet DESTINY has no direct reference process for the treatment of steel residues and will provide a product of a new quality, i.e. agglomerated and with partly reduced content of iron oxides, corresponding to iron ore sinter or iron ore pellets but with much higher degree of reduction (30-70%). On the economic side the comparison however is not straightforward. Three effects should be noted: (1) due to the local processing of residues by DESTINY brings the opportunity to directly use the hot DESTINY product in subsequent processes to maximise energy efficiency; (2) since the heating energy in the DESTINY process is provided by MW instead of fossil fuels it is obvious that the CO₂ emissions can be extensively decreased; and (3), the recycling of ZnO as by-product of the DESTINY process provides an additional advantage, since the energy consumption of the conventional zinc recycling by the Waelz-process is significant (140kg coke/t raw material).

Below, a business (lean) model canvas for MW-kiln is reported. It is just a scratch version that will need WP6 tasks to go on in order to be completed and expanded (task 6.2): new business models will be studied with the value-chains, being the archetypes of *servitisation and decentralization* models to be explored.

Indeed, DESTINY could also mitigate the bullwhip effect of complex value-chains, thanks to its characteristic of being able to adapt production to market demand. Task 6.2 will take over this analysis and proceed with the next stakeholder analysis, combining it with the market description from this report to assess the business potential of the project.

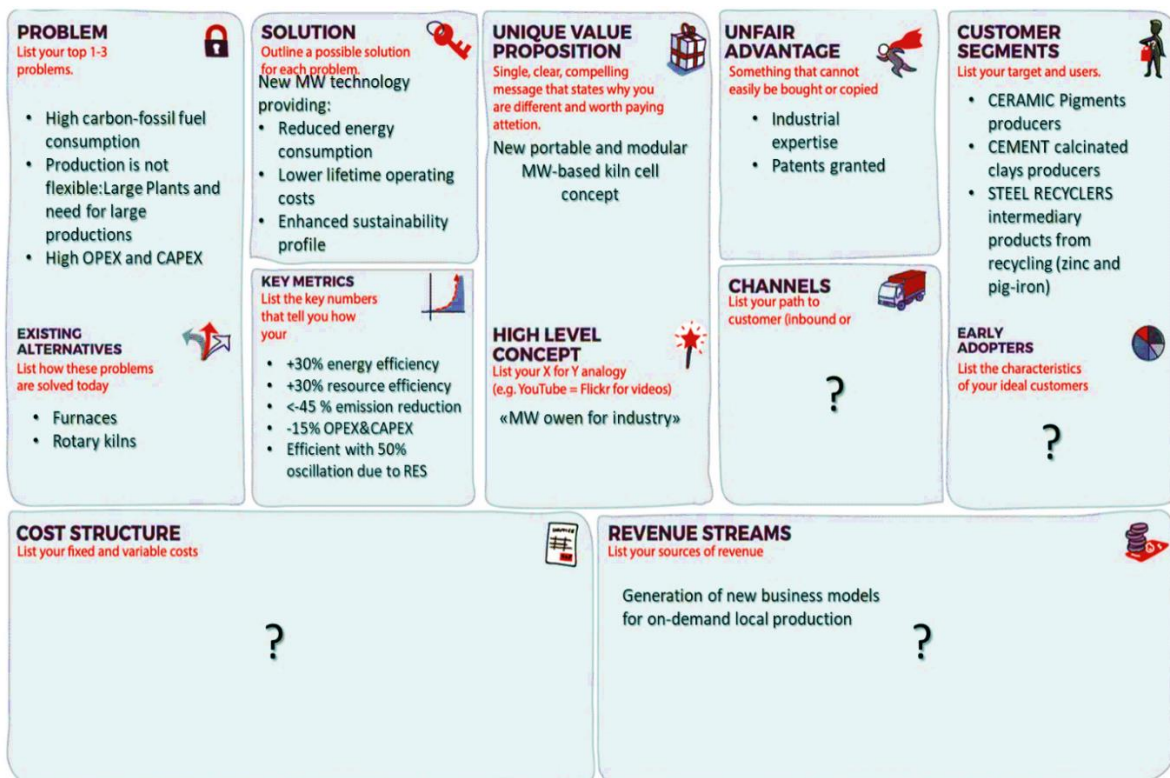

Figure 61. Scratch Lean model canvas

7 RESULTS & CONCLUSIONS

7.1 RESULTS OVERVIEW

This deliverable includes a preliminary study as a base for the value-chain, technological and business analyses to come during the DESTINY project.

By cross-checking many different sources, the report represents a unique one-stop-shop overview of cement, ceramic and steel markets including Political, Environmental, Social, Technological and Economic dimensions in one multi-sided document.

7.2 CONCLUSIONS AND NEXT STEPS

Stemming from the analysis of the innovation background and the supply-chain descriptions in this document, in the next period the Stakeholder Analysis will start and a thorough validation phase will be completed with the industrial partners within the consortium, to use this market framework for assessing the potential of the project and produce a complete technology and business study, via a knowledge-based intelligence.



8 MAIN REFERENCES

1. Cembureau, INNOVATION IN THE CEMENT INDUSTRY; **2017**
2. Cembureau, Activity Report; **2015**
3. Johanna Lehne, Felix Preston. Making Concrete Change Innovation in Low-carbon Cement and Concrete; **2018**
4. Dr. Aurélie FAVIER. A SUSTAINABLE FUTURE FOR THE EUROPEAN CEMENT AND CONCRETE INDUSTRY; **2018**
5. H. Wagner & Partner. THE EUROPEAN CEMENT INDUSTRY. **2000**
6. Mr. Giovanni Pino. BREF on Cement Industries, APAT.
7. Cembureau. The role of CEMENT in the 2050 LOW CARBON ECONOMY; **2011**
8. Bas J. van Ruijven. Long-term model-based projections of energy use and CO₂ emissions from the global steel and cement industries; Resources, Conservation and Recycling. **2016**
9. European Commission. Competitiveness of the European Cement and Lime Sectors; **2017**
10. Isabel Agudelo. Supply Chain Management in the Cement Industry; **2009**
11. WWF. A blueprint for a climate friendly cement industry;
12. J.A. Moya. Energy Efficiency and CO₂ Emissions: Prospective Scenarios for the Cement Industry; **2010**
13. European Commission. Best Available Techniques (BAT) Cement; **2013**
14. Eurofer. ECONOMIC AND STEEL MARKET OUTLOOK 2019-2020; **2019**
15. Eurofer. European Steel in Figures 2018; **2018**
16. Piotr Palimaka. Zinc Recovery from Steelmaking Dust by Hydrometallurgical Methods; **2018**
17. Worlsteel. WORLD STEEL IN FIGURES 2018; **2018**
18. European Commission. Best Available Techniques Iron and Steel; **2013**
19. Luca Baraldi, MECS. World production and consumption of ceramic tiles; **2016**
20. Ceramic Wolrld. World production and consumption of ceramic tiles; **2018**
21. Sample. Global Ceramic PigmentsMarket Report, History and Forecast 2014-2025; **2019**
22. J. Peng. CO₂ Emission Calculation and Reduction Options in Ceramic Tile Manufacture-The Foshan Case; **2012**
23. Michele Dondi. INNOVATION IN INNOVATION IN CERAMIC PIGMENTS. **2003**
24. European Commission. Best Available Techniques Ceramic; **2007**
25. Katz JD. Microwave Sintering of Ceramics. Annual Review of Materials Science. **1992**;22(1):153-70.
26. O'Holleran TP. Microwave heating for production of a glass bonded ceramic high-level waste form; **2002**.
27. Cherian K, Kirksey M, Hu P, Hurtt L, Cheng J, Agrawal D. Ride the Wave. Ceramic Industry.
28. Schulz R. Overview of Hybrid Microwave Technology. Journal of the South Carolina Academy of Science. **2011**;9(1):25.



DELIVERABLE REVIEW

REVIEWING DETAILS:

OPERATIONAL STEERING LEVEL

Reviewer Name:	LUIS GUAITA - SANDRA COLINA	Beneficiary name:	KERABEN
Consortium role:	PM		
Draft version:	Version 0.1-01	Revised version:	2019-09-30
Review version:	Version [0.1-02_KERABEN]	Reviewing date:	2019-10-15

Reviewer Name:	ANGEL LOPEZ	Beneficiary name:	CEINNMAT
Consortium role:	SC		
Draft version:	Version 0.1-01	Revised version:	2019-09-15
Review version:	Version [0.1-02_KERABEN_CEINNMAT]	Reviewing date:	2019-10-17

General Impression of deliverable:

The described information in the document is well explained for each sector involved in the project.
Easy to read and understandable for reviewers.

General Improvements:

The document is too long, due to the amount of figures. It could be advisable to gather most of them as annex.

The titles with level X.X don't have the font colour of the template and this is also happening in Footer.

Check for abbreviations and acronyms and create the List at the beginning of the document as indicated in template. Some have been marked as comments. In DATA of STEEL sector it would be good to have some general figures about Zn market (i.e. Zn or ZnO production to evaluate the impact of zinc recovery).

Please, use homogenous terminology on tonnes (i.e. "tons", "tonnes" and "metric tonnes" are in the same document). Recommendations: better use "tonne" instead "ton". Both are accepted, but "tonne" is unequivocally metric tonne. In International System the symbol of tonne is "t".

CO₂ is well understood in economy and environment, but both CO₂ as CO₂ are very mixed in same paragraph.



--

Checklist

ITEM	YES	NO	COMMENTS/REMARKS/CHANGES.
Are all deviations from the description of action are sufficiently explained?			
Does the document contains a "Summary" section, explaining clearly the objectives and context of the deliverable?	X		
Is the information showed in figures and tables clearly enough and understandable?	X		
Has the Index taken into account the suggestions from the deliverable template?	X		
Does the Index contain tables of: content, figures and tables? Is this reflecting correct pages numbers and sections names?	X		
Do All figure and tables are labelled accurately and consistently (numbering and clear captions)?	X		
The document			
Does the document contains an "objective" section, explaining clearly the purpose and structure of the deliverable?	X		
Does Footer contains the correct deliverable name and page number?	X		
Is the style of the deliverable (headings, body text, Tables and captions) in accordance with the Deliverable template?		X	The titles with level X.X don't have the font colour of the template and this is also happening in Footer.
Have the spelling and grammar completely checked?	X		
Have all hyperlinks and references been tested and worked?	X		
Does the document have a list of abbreviations and acronyms?		X	Check for abbreviations and acronyms and create the Abbreviations and acronyms List at the beginning of the document as indicated in template. Some have been marked as comments.
Are abbreviations and terminology used consistently?	X		

